

Before you start

It is recommended that all units and basins are secured to a suitably reinforced wall to ensure stability. Wall plugs supplied are only suitable for solid stone / brick wall. For plasterboard walls use specialist wall plugs, If in any doubt please consult an expert. Wear suitable eye protection when drilling. Take care when using power tools near water - the use of a residual current device (RCD) is recommended. Beware of hidden pipes or cables. Take care when drilling tiled surfaces as the drill might slip. Use a piece of masking tape to prevent the drill from wandering.

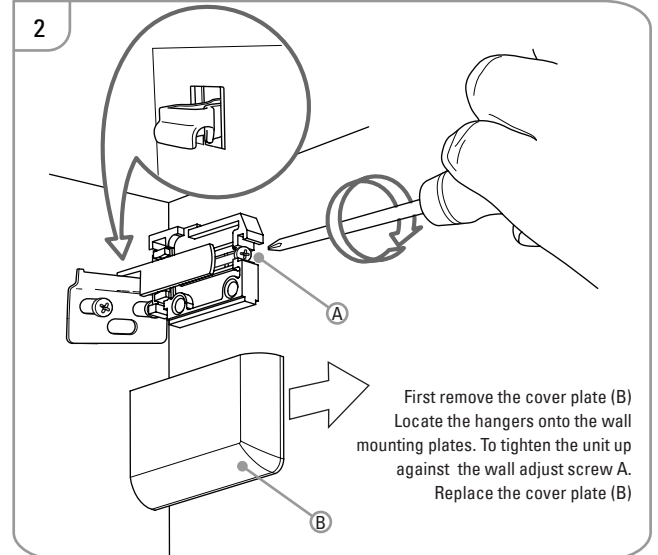
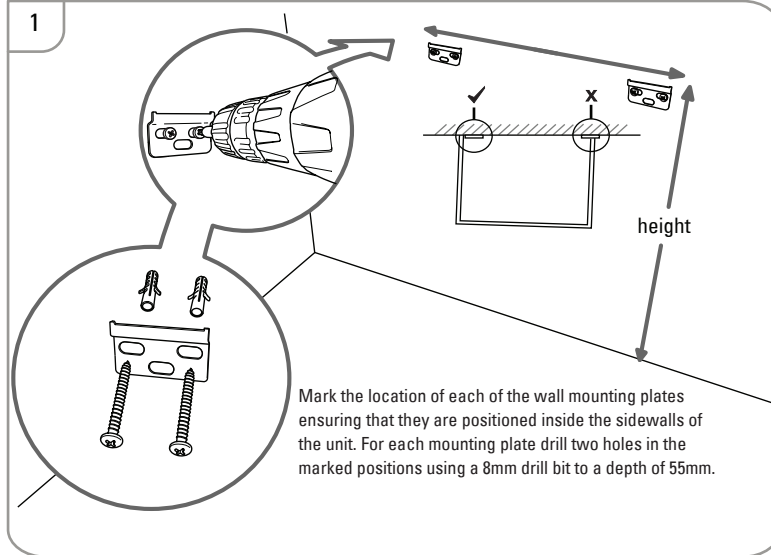

Hinge Adjustment

Hinges may require adjustment for correct door alignment. This is achieved with the adjustable soft close hinges using the adjustment screws A and B (see Drawing 3).

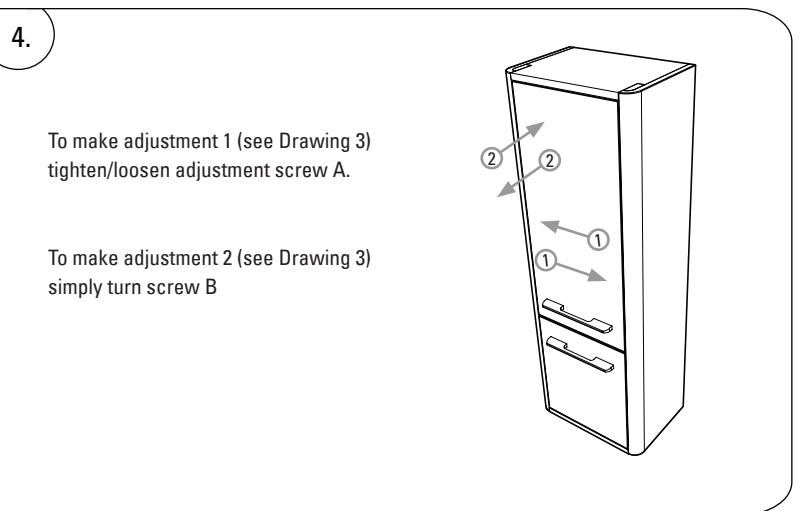
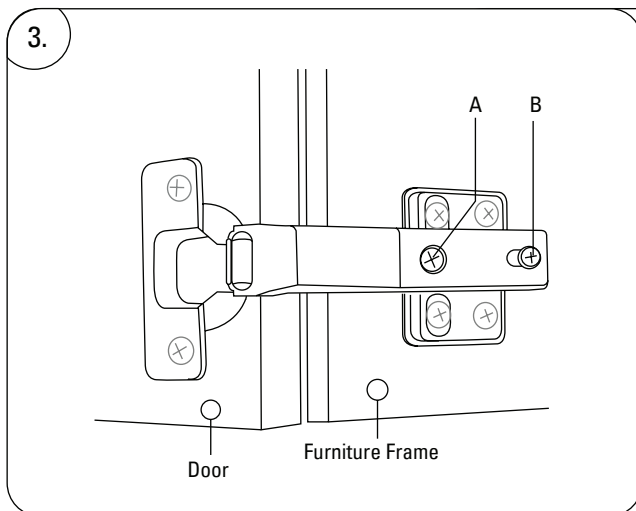

Furniture Aftercare Instructions

As with all wooden furniture, this product should be treated with care.

We recommend...

- Wipe away any water splashes or condensation after use. Excessive exposure to water will deteriorate the furniture.
- All bathrooms should be well ventilated with a suitable extractor fan.
- Clean with a soft damp cloth only.
- Use a wax free polish if one must be used.
- For removal of lime scale deposits use a suitable proprietary cleaner. If necessary test on an inconspicuous area first.

Please DO NOT...

- Do not scrub or scour
- Do not use abrasive cleaning agents

Replacement components - Should you require any replacement components for this product please contact R2 using the contact details below.