

Technical Data Sheet

RESTORE TOWEL RING CHROME

Whats in the box: 1x DC7010 & Fixings

ROPER RHODES®

Diagrams not to scale
All dimensions in mm
tolerance of +/-5mm

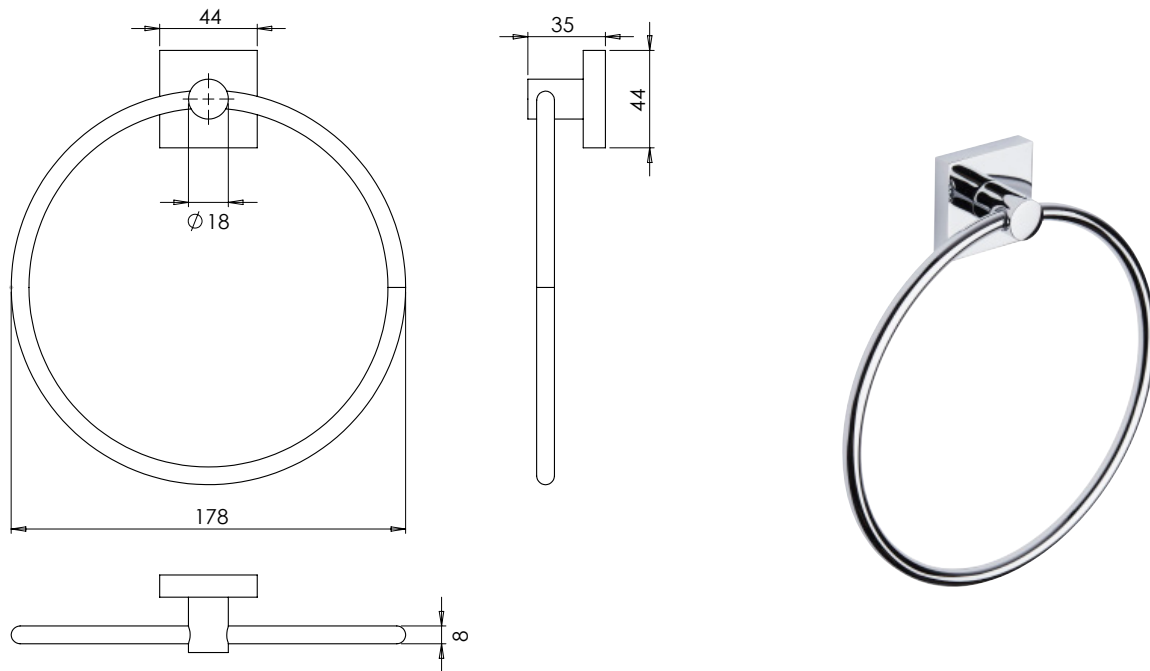

Materials

Base plate: Chrome plated brass

Holder: Chrome plated brass

**Dimensions are subject to change, customers are advised to measure actual product before commencing installation.

***Fixing point dimensions are for guidance only/the positions of wall fixing must be checked when product is received.

FAQs

Q: What is the overall distance from the wall?

A: 35 mm

Q: Coverplate dimensions?

A: 44 x 44 mm

Q: Fixing point centres?

A: 22 mm

Q: Does the product swing?

A: Yes