

Technical Data Sheet

ROPER RHODES®

FAIRMONT 1000mm FLOOR MOUNTED UNIT

What's in the box: 1x FAIRMONT 1000mm + Fixings

*Reference basin TDS for further info

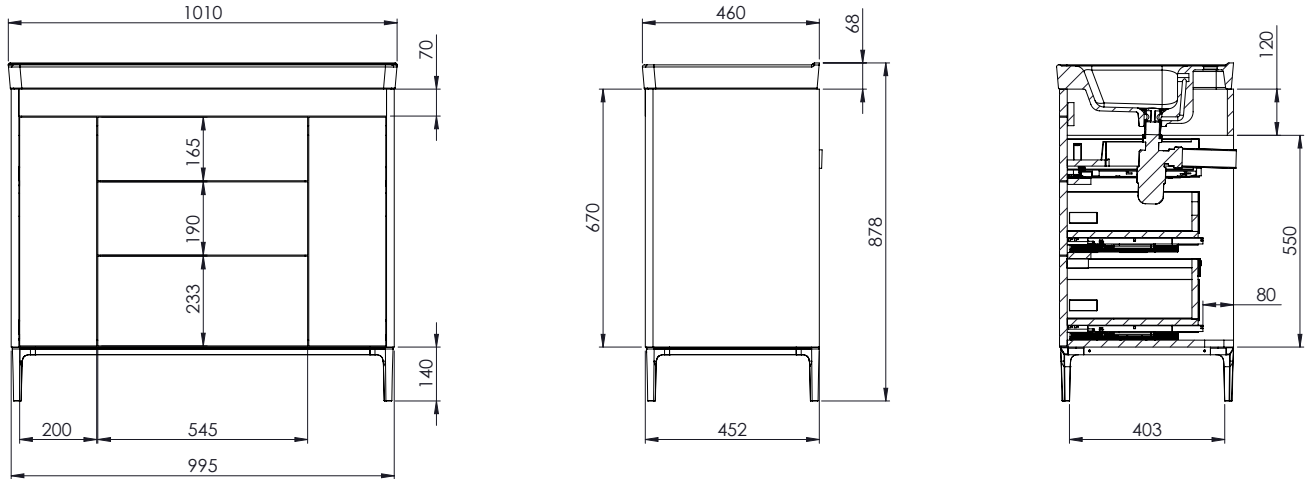

Materials

Carcass: 16mm, 18mm and 20mm Painted & Melamine faced MDF
Fascia Components: 20mm Painted MDF

Diagrams not to scale
All dimensions in mm
Tolerance of +/-5mm

**Dimensions are subject to change, customers are advised to measure actual product before commencing installation.
***Fixing point dimensions are for guidance only/the positions of wall fixing must be checked when product is received.

Extra Dimensions

Internal Drawer Depth - Front to Back:	324mm (Slim Drawer: 274mm)
Internal Drawer Height:	55mm (Top) 102mm (Middle) 156mm (Bottom) (Slim Drawer: 60mm (top) 102mm (bottom))
Internal Drawer Width:	492mm (Slim Drawer: 153mm)
Drawer Cut Out (W&D):	150mm x 240mm

FAQs

Q: Can the unit be purchased without legs?	A: Yes, the unit can installed wall hung without legs.
Q: How big is the plumbing void?	A: 80mm. The base panel has cut out for pipe work allowance.
Q: Are the handles fitted?	A: No, there are two handle options for which the holes need drilling. Please refer to handle template provided.
Q: Are the runners soft close?	A: The runners are both soft close and quick release.
Q: How deep is the unit when the drawers are fully open?	A: Approx: 750mm.
Q: Can the drawers be adjusted?	A: The drawer fascia's can be adjusted as detailed in the supplied instructions.
Q: Do the legs come pre-applied for furniture?	A: No - refer to instructions for installation method.
Q: Does the customer have to assemble leg components?	A: Yes, refer to instructions for installation method.
Q: What is the interior finish of the unit?	A: The unit interior finish is dark grey except for the side panels which match the exterior finish.

NOTE: Colours unique to Roper Rhodes - No RAL Code available