

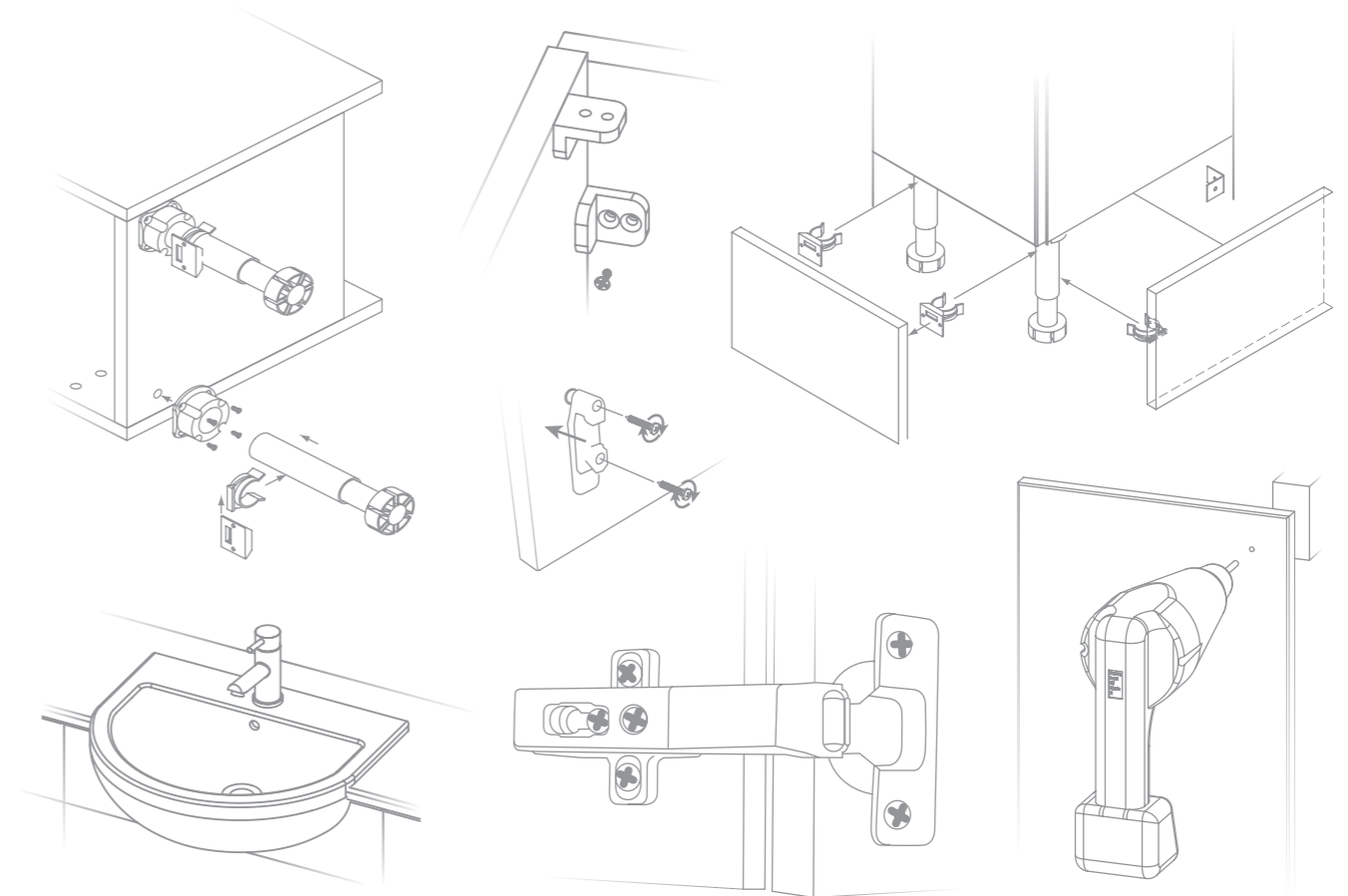

ROPER RHODES



FITTED FURNITURE INSTALLATION AND AFTERCARE GUIDE

ROPER RHODES

Customer Services Department, Roper Rhodes Ltd, Brassmill Lane Trading Estate, Bath, BA1 3JF
T: 01225 334148 | F: 01225 448877 | E: info@roperrhodes.co.uk | www.roperrhodes.co.uk

Please read these instructions before commencing work and keep them for future reference.

If you are not the end user, please pass these instructions on to the relevant person when the installation is complete.

- Roper Rhodes Fitted Furniture must be installed by a qualified fitter. In the unlikely event that your product is damaged or faulty in any way, this must be notified on receipt, and must not under any circumstances be fitted. Time must be allowed between delivery and installation for checking items and the delivery of subsequent replacements.
 - Components/products that are deemed defective as a result of incorrect or substandard installation or improper or negligent use will be excluded from any warranty claim.
 - Always unpack units carefully from the packaging and check the contents before discarding the packaging as some items may have come free and still be in the carton.
 - Do not carry units by their struts/rails.
 - Do not compress carcasses or other items up against walls as this may affect the opening action of doors and/or drawers.
 - Doors are supplied un-drilled for handles due to the wide variety of handles and possible positions. Any competent fitter will be able to fit them in the positions that best suit the design of your individual bathroom.
 - Only use low-tack masking tape to prevent marking or damaging laminate surfaces.
 - Roper Rhodes bathroom furniture is designed for use within domestic installations that are adequately ventilated. As with any timber product, bathroom furniture will be adversely affected if it is subjected to excessive moisture. Adequate bathroom extractor fans must be installed to prevent heavy condensation and all splashes and spillages MUST be mopped dry as soon as possible.
 - All exposed or cut surfaces MUST be sealed with a suitable varnish or silicone sealant to prevent blowing. If this is not done, all warranty claims will be void. Silicone sealant must be used in particular around basins and worktop joints, and around all edges of bath panels and plinths if a sealer strip is not utilised.
 - All units must be individually fixed to the wall via the adjustable hanger brackets. If units are screwed together, every unit must still be individually anchored to the wall, using the hanger brackets and suitable wall fixings.
 - Wall fixings supplied are only suitable for brick/concrete walls.
- For other wall types use appropriate wall plugs or fixings. If in doubt consult an expert.
- When wall hanging units a firm fixing must be achieved. It is the responsibility of the installer to make sure that any fixings used are suitable for the individual installation in question. If a firm fixing is not achievable with base units then the additional use of the adjustable support legs is recommended.
 - All electrical products should be installed in line with current wiring regulations by an approved electrician. Specialist instructions are supplied with all electrical products.
 - Roper Rhodes Ltd reserve the right to amend the specifications at any time if an opportunity to further improve the product occurs. All dimensions are approximate and are quoted within reasonable tolerances.
 - Always wear suitable eye protection when drilling holes in the wall.
 - Take care when using power tools near water - the use of a residual current device (RCD) is advised.
 - Beware of hidden cables or pipes.
 - Take care if drilling on tiled surfaces in case the drill slips. A piece of masking tape applied to the wall before marking out the fixing holes will stop the drill from wandering.
 - All items within the range could be dangerous if installed incorrectly and installation is only to be carried out by a competent person.
 - Glass Warnings: Do not strike glass components with hard or pointed items. Do not place very hot or very cold items against or in close proximity to glass surfaces unless an adequately thick insulation material is used to prevent such items coming in contact with the glass. If a glass component becomes chipped or broken, replace immediately. For details on replacement glass contact Roper Rhodes customer services at the address stated on these instructions
 - Never overload shelves or units. If necessary due to site conditions, use additional supports/battens/brackets to provide additional support to units (not supplied).

Leg Fitting (for installations with continuous plinths)

Lay the units on to a clean flat surface so that the sides are not scratched or damaged.

If a wall-hung look is not required (or achievable due to site conditions), attach the black socket of the legs into the base of the unit and secure in position with the screws provided. Ensure that the flat sides of the leg socket run parallel to the front and side of the unit.

Push the legs into the socket – they may need a tap with a hammer to achieve a secure fit.

Adjust the legs to allow a space of approximately 180mm between the underside of the unit and the floor to accommodate the plinth (add 2mm to allow for the fitting of plinths with a sealer strip if necessary).

Once all necessary pipe work is completed, position the unit on its legs and against the wall. Ensure that the unit sits level in both directions. Make any notches as necessary for pipe runs that run along the back of the furniture units.

Note: Do not drag the unit across the floor – this will damage the carcass where the legs are fastened.

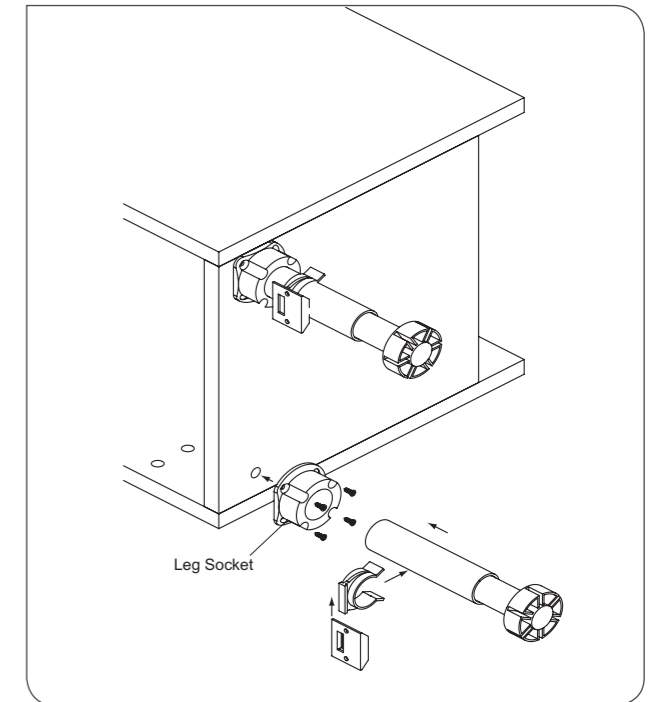

Leg Fitting (WC Units)

Lay the units on to a clean flat surface so that the sides are not scratched or damaged.

A wall hung look with WC units is not practical due to pipe work requirements. Attach the black socket of the legs into the inside of the unit and secure in position with the screws provided.

Push the legs into the socket – they may need a tap with a hammer to achieve a secure fit.

Adjust the legs to allow a space of approximately 180mm between the underside of the unit and the floor to accommodate the plinth (add 2mm to allow for the fitting of plinths with a sealer strip if necessary).

Once all necessary pipe work is completed, position the unit on its legs and against the wall. Ensure that the unit sits level in both directions. Make any notches as necessary for pipe runs that run along the back of the furniture units.

Note: Do not drag the unit across the floor – this will damage the carcass where the legs are fastened.

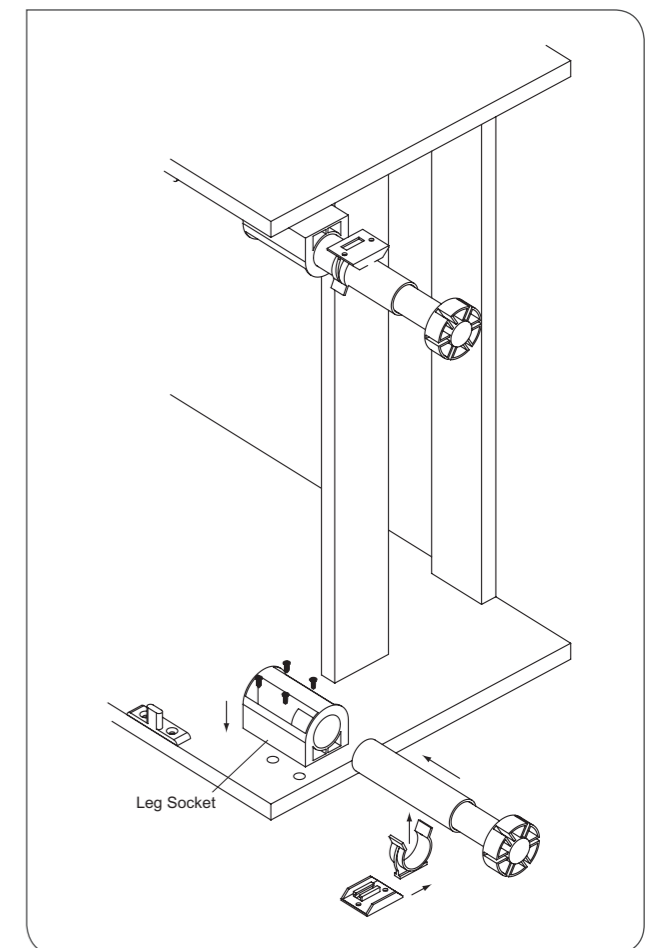

Chrome Display Legs (for contemporary installations without continuous plinth)

Dispose of the plastic legs that come with the unit.

Using the same pilot holes on the base of the unit, screw the legs using the screws supplied, fixing legs where required on a run of furniture. The leg can be adjusted slightly for uneven floors. Once all necessary pipe work is completed, position the unit on its legs and against the wall.

Ensure that the unit sits level in both directions. Make any notches as necessary for pipe runs that run along the back of the furniture units.

Note: Do not drag the unit across the floor – this will damage the carcass where the legs are fastened.

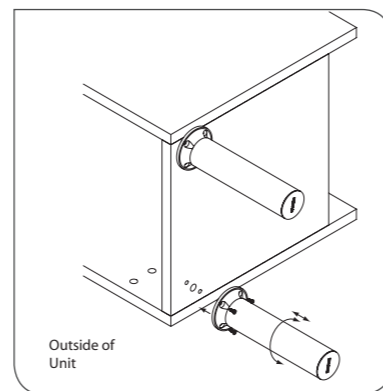

Hanging Units with Claw Hangers

Where necessary remove the small white transit feet from the base of the unit by prising off carefully with a screwdriver.

Once the base unit is level, each one must be anchored to the wall using the adjustable hanging brackets at the back of the unit. Draw a line on the wall with a spirit level where the nominal height of the top of the unit should be – this will make adjustment to the suitable level easy once the unit is hung.

Loosen off both the screws on the hangers and position the metal wall plate on the wall at the suitable height for the unit in question (distance x). See right.

Note: Nominal height from floor to the top of base units (excluding worktop) is 820mm (*822 if plinth sealer strip is used).

Nominal height from floor to the top of a full height unit is 1900mm (*1902mm if plinth sealer strip is used).

Note: If using the 50mm leg extension for higher plinths, add 50mm (or necessary amount) to nominal heights. The 2m bridging panel doubles up as a 230mm high plinth for installations where higher clearance over pipe work is required.

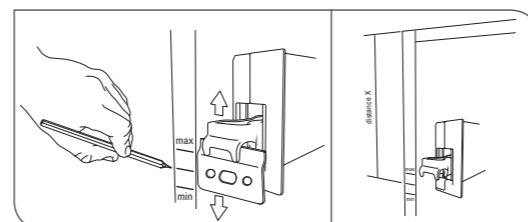

Slacken off the wall hanger and offer up the wall plate. Mark the mid point between the maximum and minimum height of the wall plate hole centres. Measure the distance from the top of the unit and mid point marked previously. This is distance x.

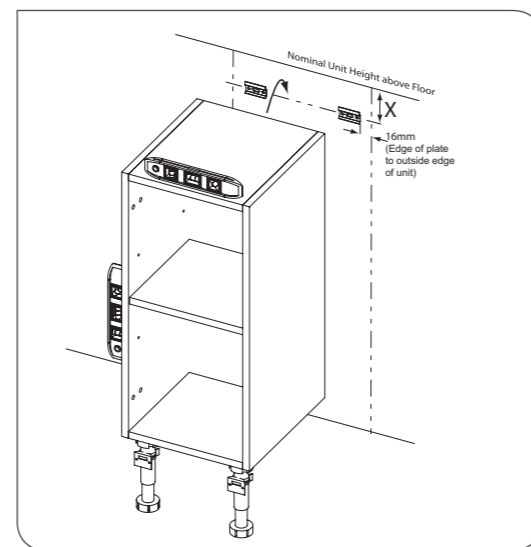

Nominal Heights to tops of units (excluding worktops)

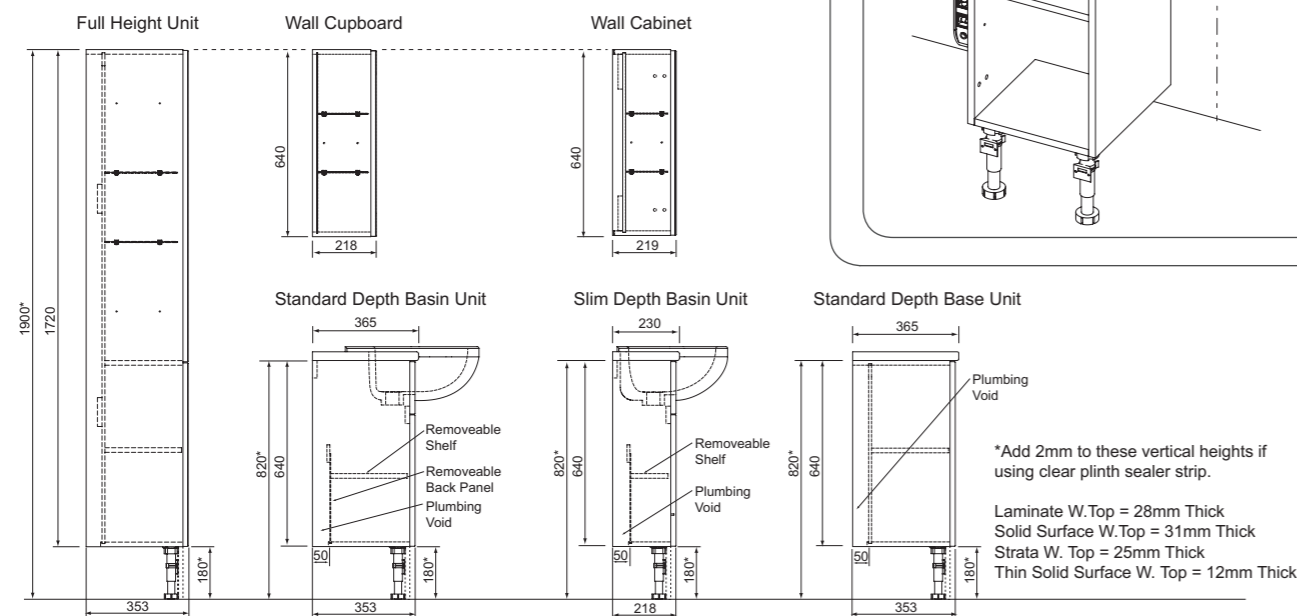

Fasten the metal wall plate using the appropriate fixings for the wall in question. Note: Fixings supplied are only suitable for stone/brick walls.

Hang the unit onto the metal wall plate, making sure that the claw of the hanger locates properly. Adjust the level of the unit using screw (A) as shown. Once level, secure the unit to the wall by tightening the lower screw (B).

Adjoining units can be connected together using the connecting bolts supplied. Drill through units once fastened to the wall and properly aligned. Use a wooden block on the inside of the adjoining unit to drill into.

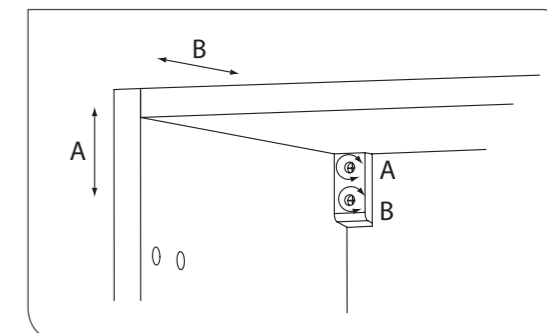

Hanging Units with Concealed Hangers

It is recommended that glass shelves are removed from units before installing.

Wall units must each be anchored to the wall using the concealed adjustable hanging brackets at the back of the unit. Draw a line on the wall with a spirit level where the nominal height of the top of the unit should be – this will make adjustment to the suitable level easy once the unit is hung.

Loosen off the metal button on the back of the hanging bracket on the unit and offer up the metal wall plate. Mark the mid point between the maximum and minimum height of the wall plate hole centres. Measure the distance from the top of the unit and mid point marked previously. This is distance x.

Note: Nominal height from floor to the top of wall cupboards, cabinets and mirrors is 1900mm. Adjust the height if running the units off from a full height unit.

Fasten the metal wall plate using the appropriate fixings for the wall in question. Note: Fixings supplied are only suitable for stone/brick walls.

Hang the unit onto the metal wall plate, making sure that the metal button of the hanger locates properly on to the metal plate. Adjust the level of the unit using screw (A) as shown. Once level, secure the unit to the wall by tightening the lower screw (B). Then fix the cover plate inside the unit.

Adjoining units can be connected together using the connecting bolts supplied. Drill through units once fastened to the wall and properly aligned. Use a wooden block on the inside of the adjoining unit to drill into.

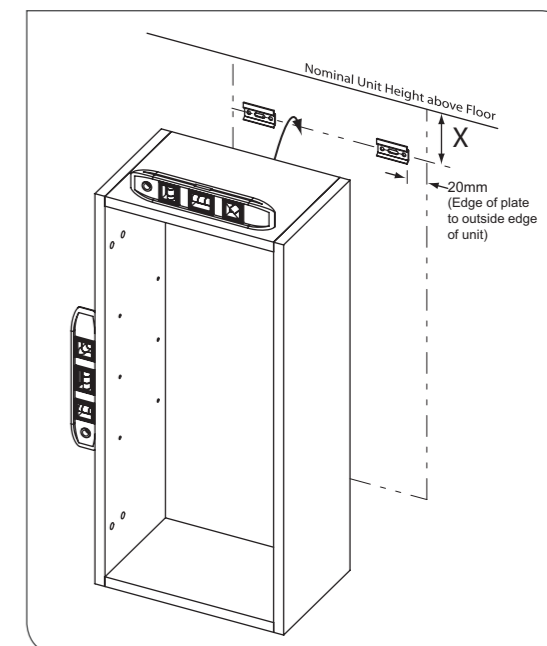
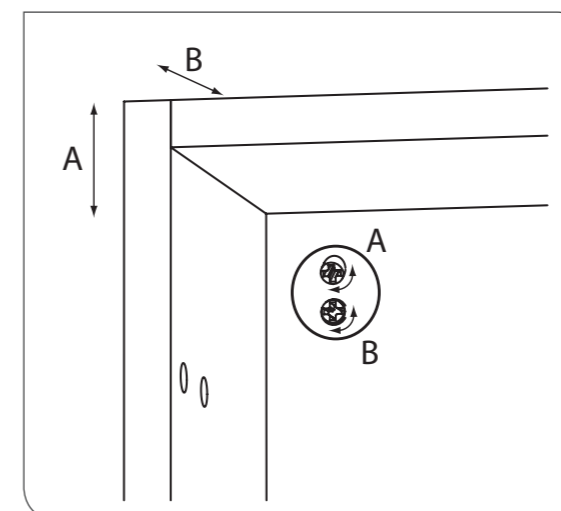
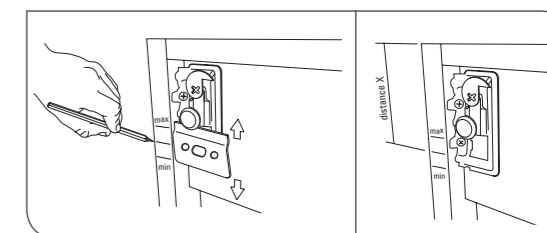
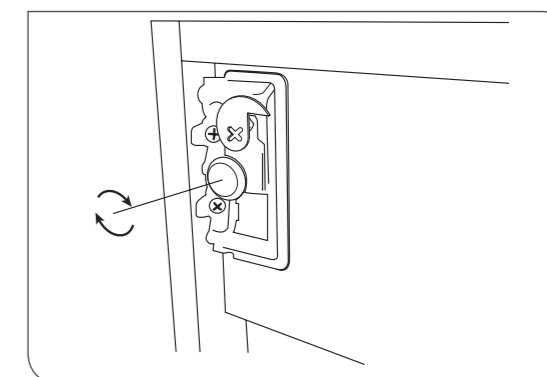

Door / Hinge Fixing (All units excluding Toilet Roll Holder Unit, Mirror Wall Cabinets and Curved Basin Units)

Screw the hinges supplied with the unit to the corresponding door, using the screws provided.

Clip Hinge into the front of the mounting plate on inside of unit first before pushing the back of the hinge against the plate until it clips into position.

Adjust the door as necessary – see diagram. To adjust the door left and right, tighten / loosen screw (1). To adjust the door forwards and backwards tighten / loosen screw (2). To move the door up and down adjust the screws on the hinge mounting plate (3).

Note on single door units that doors can be reversed (do so before drilling for handles). Fasten the hinge plates on the desired side of the unit. Use the cover stickers provided in the fixing pack to cover the original hinge plate holes.

Press the decorative cover plates over the top of the hinges.

The door can be easily removed by pushing the Quick release tab (see diagram) and swinging the back of the hinge away from the mounting plate. Always remove the bottom hinge first.

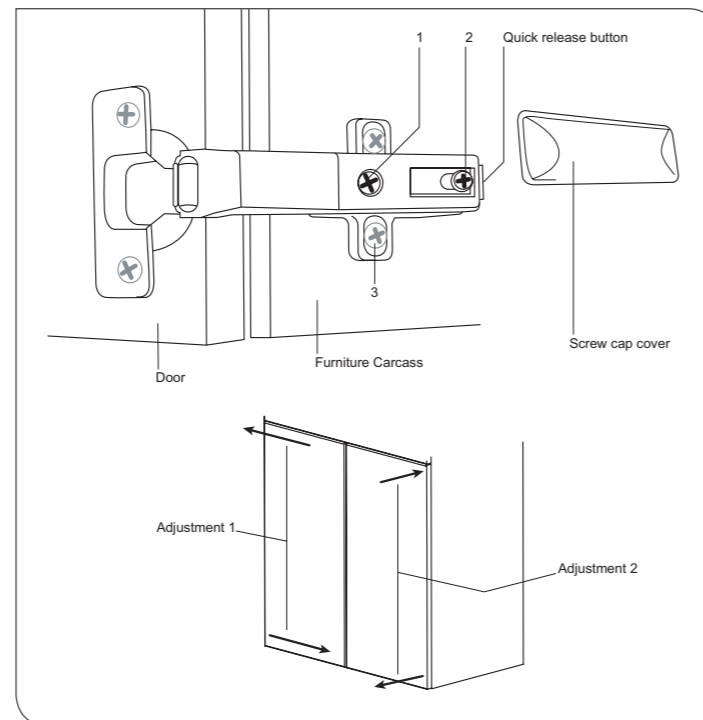

Door / Hinge Fixing (Toilet Roll Holder Units).

Knock the hinges supplied with the unit into the corresponding door, knocking gently with a hammer.

Screw the hinge mounting plates to the inside of the unit, making sure that they face the right way (see diagram). Note that if using the legs for continuous plinths, the leg socket must be fitted before the hinge plate is mounted inside the carcass.

Fix the hinge to the mounting plate on the inside base if the unit, and adjust as necessary as detailed above.

Screw the door support arm to the back of the door – screwing into the pilot holes as necessary.

Fasten the toilet roll holder to the back of the door - screwing into the two pilot holes on the back of the door.

Hinges can be adjusted as shown above. However, due to the different hinge orientation, screw (1) will adjust the door up and down, (2) will adjust the door from front to back, and (3) will adjust the door from left to right.

Press the decorative cover plates over the top of the hinges

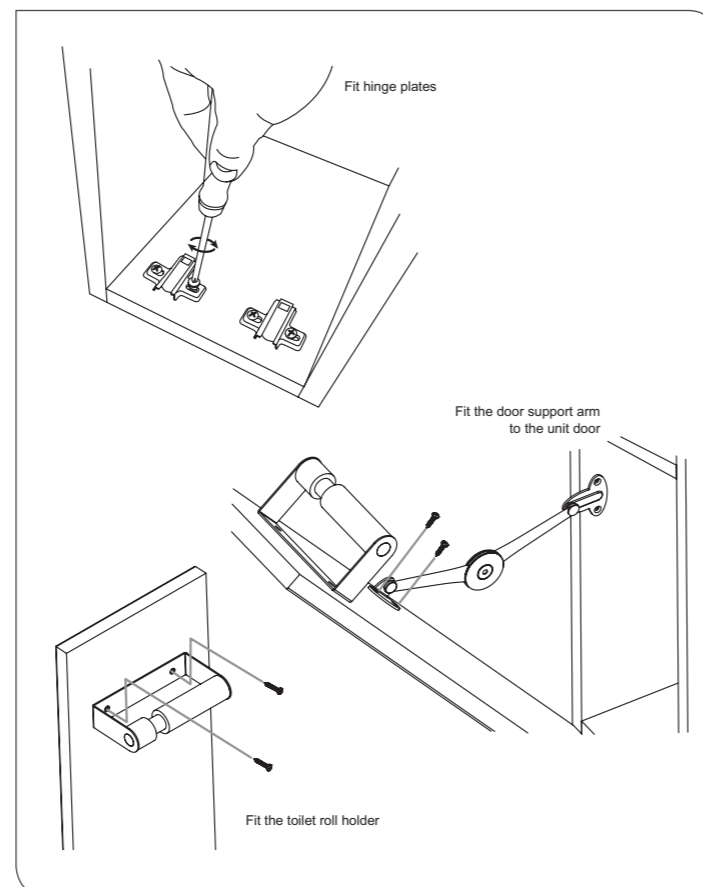

Door / Hinge Adjusting (Mirror Wall Cabinets)

Doors come ready assembled on mirror wall cabinets. To remove the door, unscrew Screw (2) (see diagram). To adjust the door from left to right, adjust Screw (1). To adjust the door from front to back, loosen Screw (2) and slide the hinge forward / backward into position. After adjustment is complete press the decorative cover plates over the top of the hinges.

Note on single door units that doors can be reversed. Simply unscrew the hinge plates from one side of the carcass and fasten into the pre-drilled holes on the other side. Use the cover stickers provided in the fixing pack to cover the original hinge plate holes.

Note that doors may move slightly in transit. To achieve optimum performance from the dab mechanism to open/close the door, the door may have to be adjusted slightly by moving the hinge forwards (screw 2).

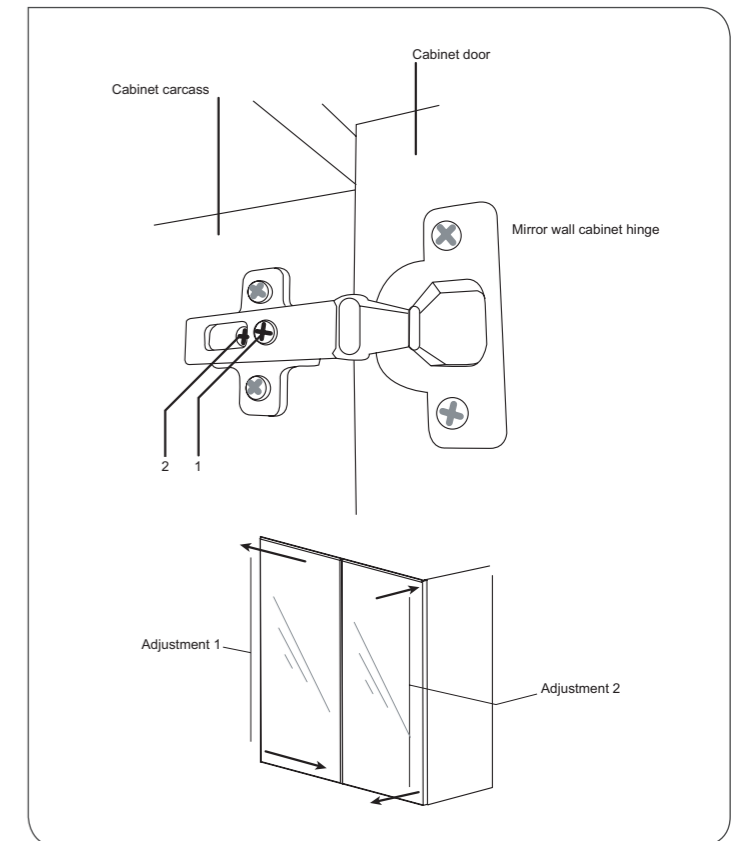

Door / Hinge Fixing (Curved Door Basin Unit)

Screw the hinges to the doors using the hinges provided with the Curved Door Basin Unit. Fasten the hinges to the mounting plates inside the carcass and secure by tightening Screw 2.

The doors can be adjusted as shown in the diagram. To adjust the doors left and right, adjust screw (1). To move the doors in and out adjust screw (2).

The doors can be adjusted up and down by adjusting the screws on the hinge mounting plate where it mounts onto the carcass (3).

Note that with curved doors it may be necessary to adjust different screws to achieve optimum door alignment.

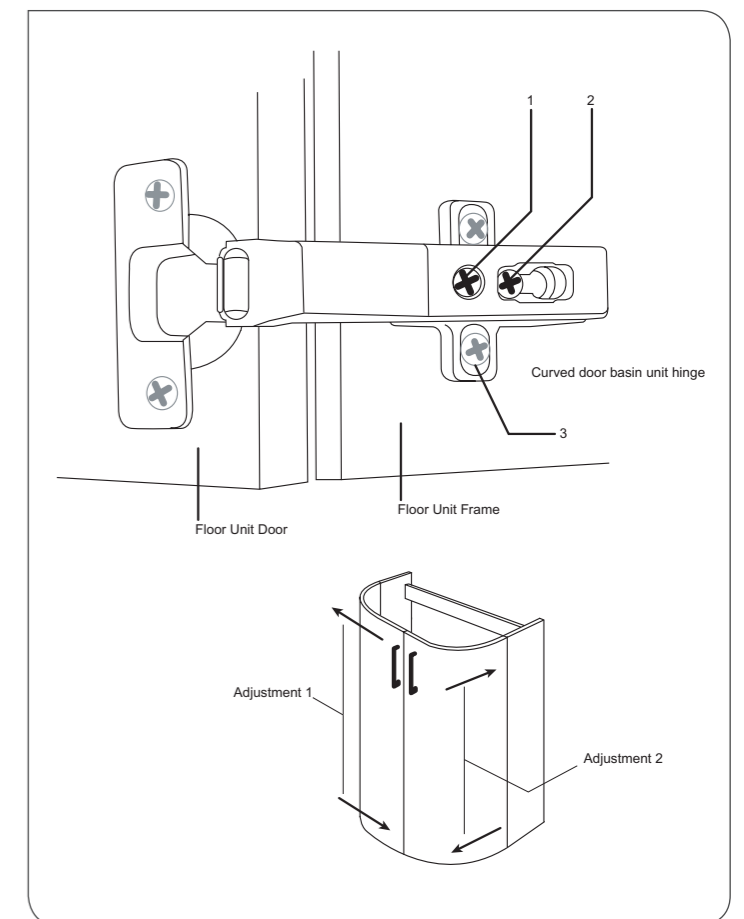

Drawer Fascia Mounting & Adjustment

Drawer fascias are supplied separately to the corresponding drawer units to prevent them from being damaged during the installation process.

Simply push the corresponding plastic fascia mounting blocks onto the back of the drawer fascia. Then push the fascia into position onto the drawer, making sure that the white mounting blocks click into place.

For deep (base) drawers, screw the round rail mounts into the pilot holes at the top of the drawer. Clip the rails onto the back top corners of the drawer and clip the fronts of the rails into place into the rail mounts on the back of the fascia.

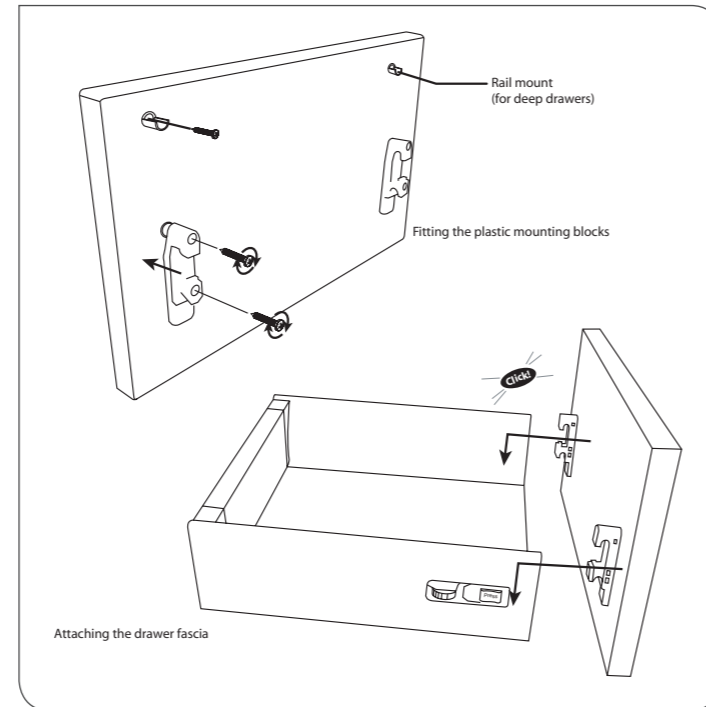

Drawers can be simply removed from the units by releasing the clips on the underside of the drawer runners (see diagram).

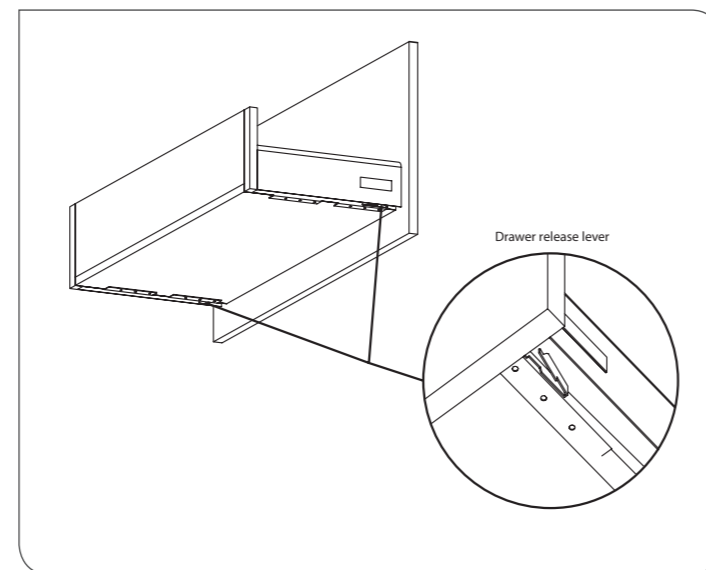

Drawers are easily adjusted using the adjustment panels on the side (see diagram). First remove the plastic cover plate to reveal the controls (1 on each side of the drawer).

Button A - Releases the drawer fascia from the draw frame (press on both sides).

Screw B - Moves the drawer fascia left / right (there is only one Screw B per drawer which is located on the adjustment panel on the right hand side).

Wheel C - Moves the drawer fascia up / down (one wheel on each side of the drawer).

For deep drawers with rails, the drawer fascia can be adjusted in/ out at the top by rotating the rails.

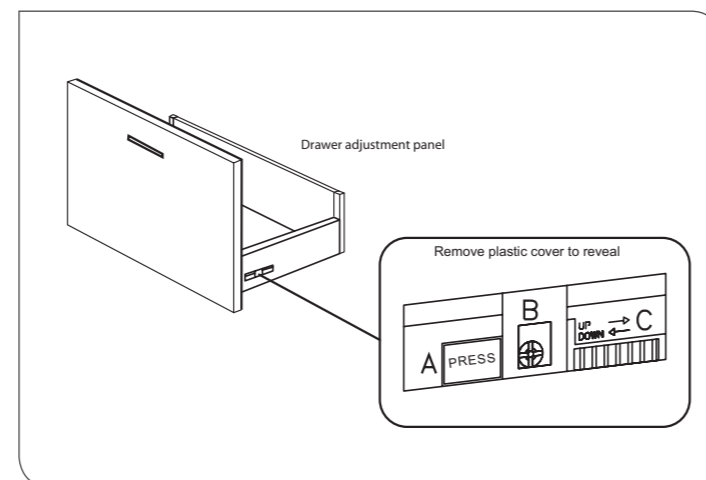

WC Unit Installation

Hang the WC units in accordance with the instructions on P4/P5. Determine the concealed cistern position in accordance with the manufacturer's instructions supplied with the cistern.

Note that the 2 pilot holes in the back rail are in the correct position for the Geberit Montage low level dual flush concealed cistern when the unit is mounted at the nominal height with a standard plinth. It may be necessary to fix the cistern with additional battens screwed to the rear wall.

WC Unit Fascia Panel Fixing

Screw the black Keku hook clips (x4) into pilot holes on the back of the main fascia panel, using the short screws supplied, ensuring that they are in the correct orientation.

Locate the main panel onto the black Keku retaining posts inside the unit, and push down to secure.

Screw the black female Keku clips (x2) into the pilot holes on the back of the top fascia panel as shown, ensuring that they are in the correct orientation. These are shipped on the top clips attached to the unit.

Ensuring that the main panel has been fitted first, locate the top fascia panel from the front of the unit, making sure that the clips engage with the clips inside the unit. The clips are designed such that the top fascia panel can be removed for future access to the concealed cistern. If necessary use a suitable tool to insert in behind the panel to allow it to be pulled off.

Fitting Sanitaryware

Make cut outs in the main panel as necessary for the inlet pipe from the cistern and the waste (soil) pipe, as per the manufacturer's instructions.

All cut edges must be resealed with a suitable oil based paint or PU lacquer to prevent water ingress.

Note that wall hung toilets must not be bolted only to the fascia panel of the WC Unit as this will not provide adequate support. A suitable wall hung frame must be used instead – refer to the instructions supplied with the wall frame. If necessary the lower rail in the WC unit can be cut out to accommodate a wall frame if necessary. With the 600mm wide std depth WC unit, the higher support strut for a concealed cistern can be moved to the rear of the unit to allow a frame to be fitted directly through the rail and into the wall.

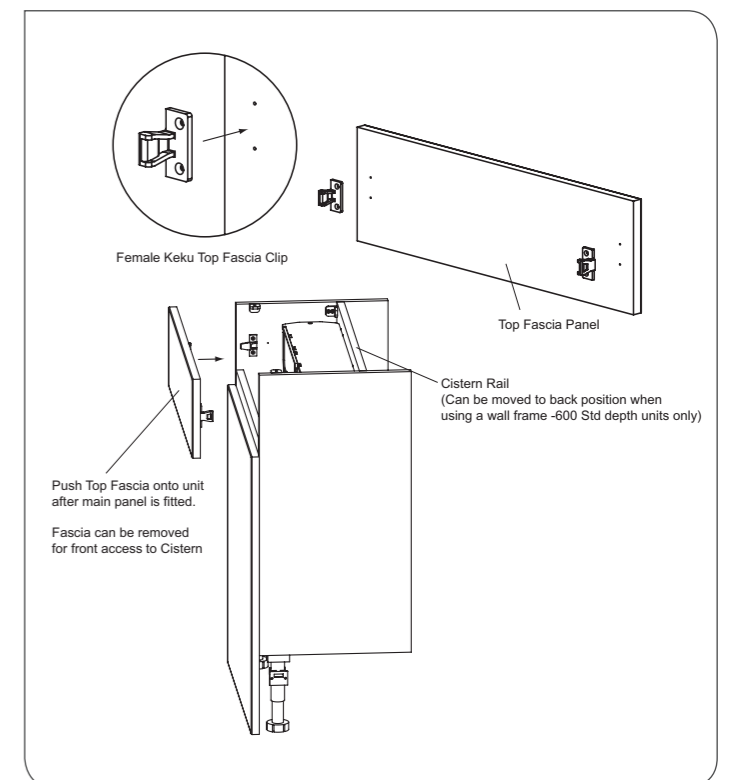
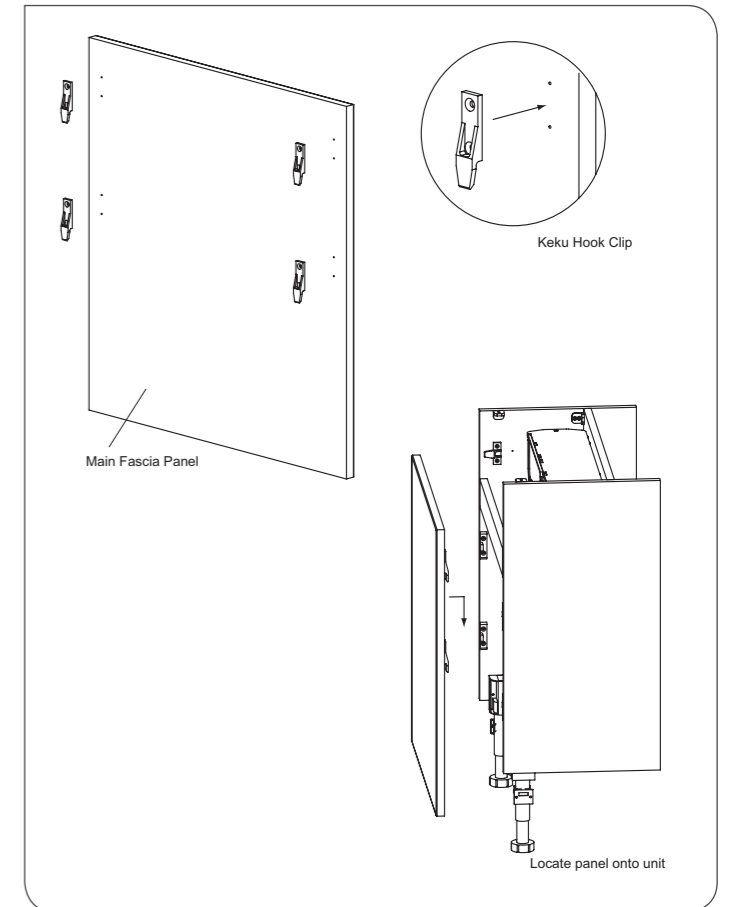

Push Button Locating

The top fascia will need to be cut with a suitably sized hole cutter. Before cutting make sure that the button does not obstruct the cistern.

If fitting the Geberit Montage cistern inside the Slimline WC Units, the hole for the push button must be located on the fascia as detailed (see below) for the slim depth WC units. The cistern must be located in to the pilot holes on the cistern rail however. This is to ensure that the push button assembly locates in the aperture of the cistern (see right) due to the restriction of space. If the cistern is mounted at a different height adapt the position of the button on the fascia as necessary.

There are no restrictions to the location of the push button on fascias of standard depth WC Units.

Note: The horizontal dimensions can be reversed if the access panel on the front of the Geberit cistern is mounted on the other side, depending on personal preference.

Basin Units

Fit the top fascia to the basin unit on both sides using the keku brackets provided.

When fixing a basin to the worktop above a basin unit, ensure that the back of the basin mates against the front surface of the fascia. Remember to account for the worktop thickness and overhang when aligning the basin template. Cut out the worktop and fascia in accordance with the instructions supplied with the basin.

All cut edges **MUST** be resealed with a suitable waterproof varnish, oil based paint or lacquer. Once installed, the basin must be sealed around all edges with a quality silicone sealant.

If fitting a solid surface basin cowl to the front of the unit, cut the fascia as necessary, sealing as above, and fasten the cowl in accordance with the instructions supplied with your solid surface basin top. **NOTE:** Worktop will need to be notched on either side (shown A below) so that the basin fits flush to the fascia.

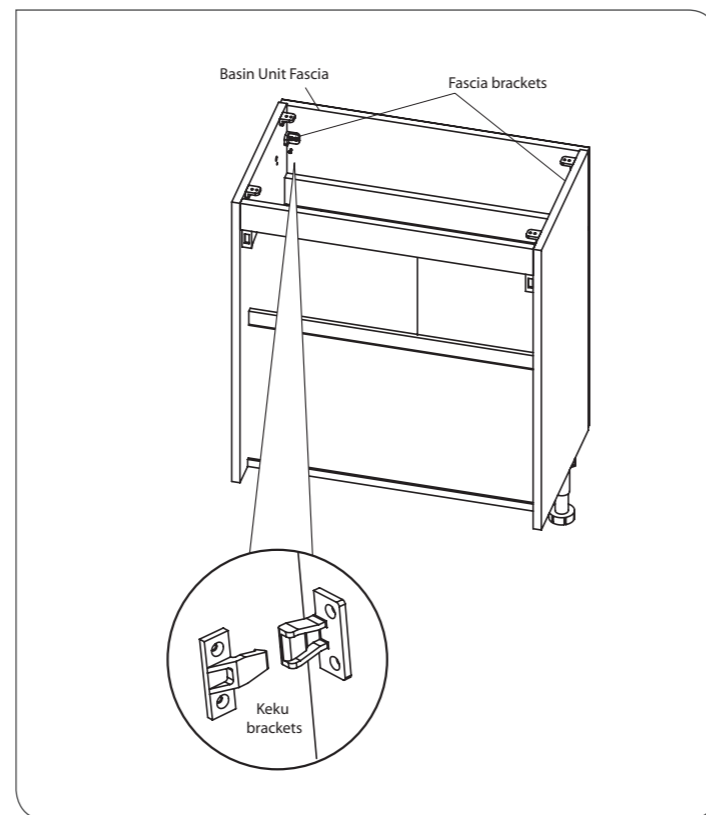
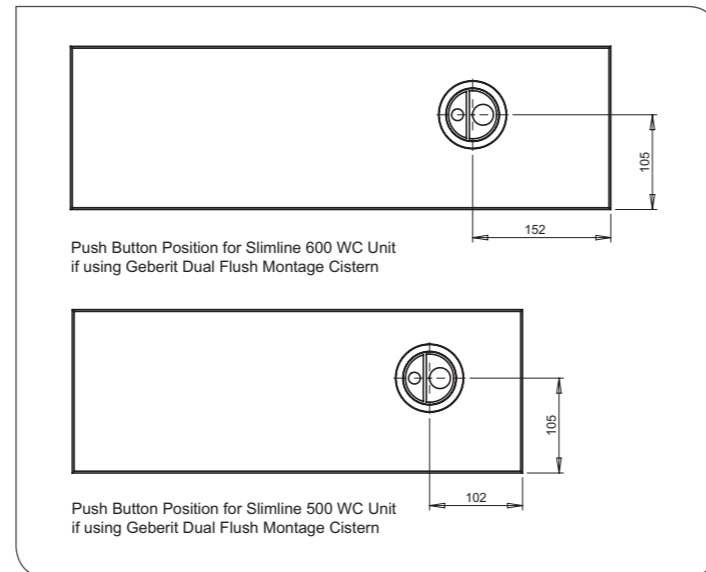
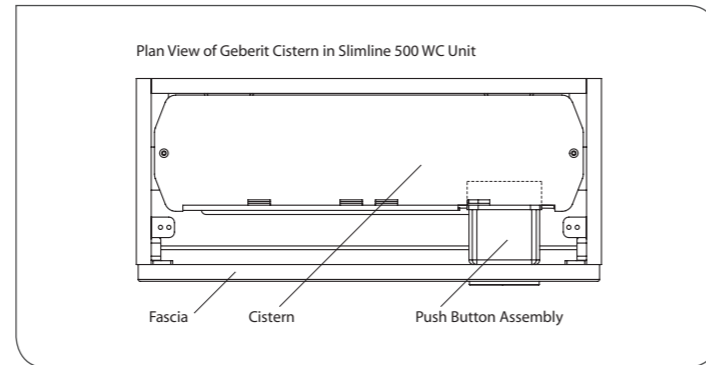
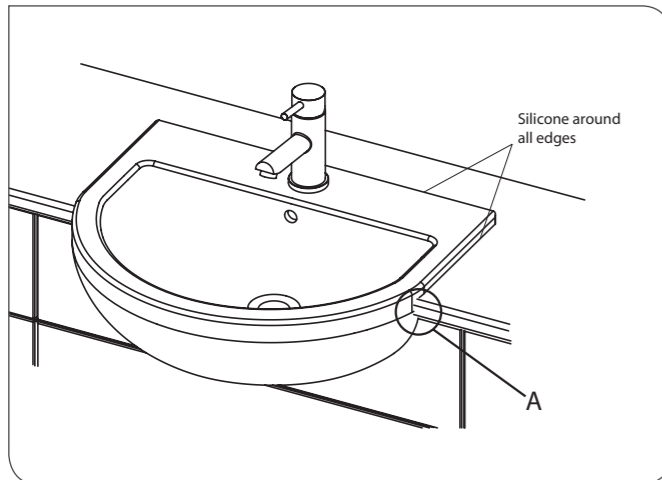

Shelf Storage Units

The shelf storage units (available in both standard and slim depth configurations) can be cut down to size if necessary before final assembly so that odd gaps in a run of furniture can be filled without wasting valuable storage space.

The slim depth version can also be used above worktop level with wall cabinets/cupboards if required.

As the top and base panels can be cut down, 3mm diameter pilot holes will need to be drilled in the ends before screwing together. Use the side panel as a template.

The nominal width of both units is 300mm. If a gap of 250mm is available in the run of furniture for example, then remove 50mm of material from the top and the base as well as the shelves. The back panel will also need to have 50mm of material removed. Remember to cut a suitable slot in the back panel to go around the hanger bracket and to allow for the width of the cutting blade.

Once assembled, cover any screw heads with the cover caps provided.

All cut edges **MUST** be resealed with a suitable waterproof varnish, oil based paint or lacquer.

Shelf Storage Unit Components

- 2x Side Panels (A)
- 1x LHS Hanging Bracket (B)
- 1x RHS Hanging Bracket (C)
- 1x Base Panel (D)
- 1x Top Panel (E)
- 2x Internal Shelves (F)
- 1x Back Panel (G)
- 12x CSK Cap Head Self Tapping Screws (M5 x 50mm) (H)
- (8 with Slimdepth unit)
- 8x Shelf Supports (J)
- 2x Unit Connecting Bolts
- 2x Wall Hanger plates
- 4x M8 Wall Plugs
- 4x M5x50mm Posidrive Screws
- 1x Leg Bag (including):
- 2x Leg Sockets (K)
- 2x Legs (L)
- 3x Plinth Clips (M)
- 2x Angle Brackets
- 16x M3x12mm CSK Screws
- 2x Return Brackets

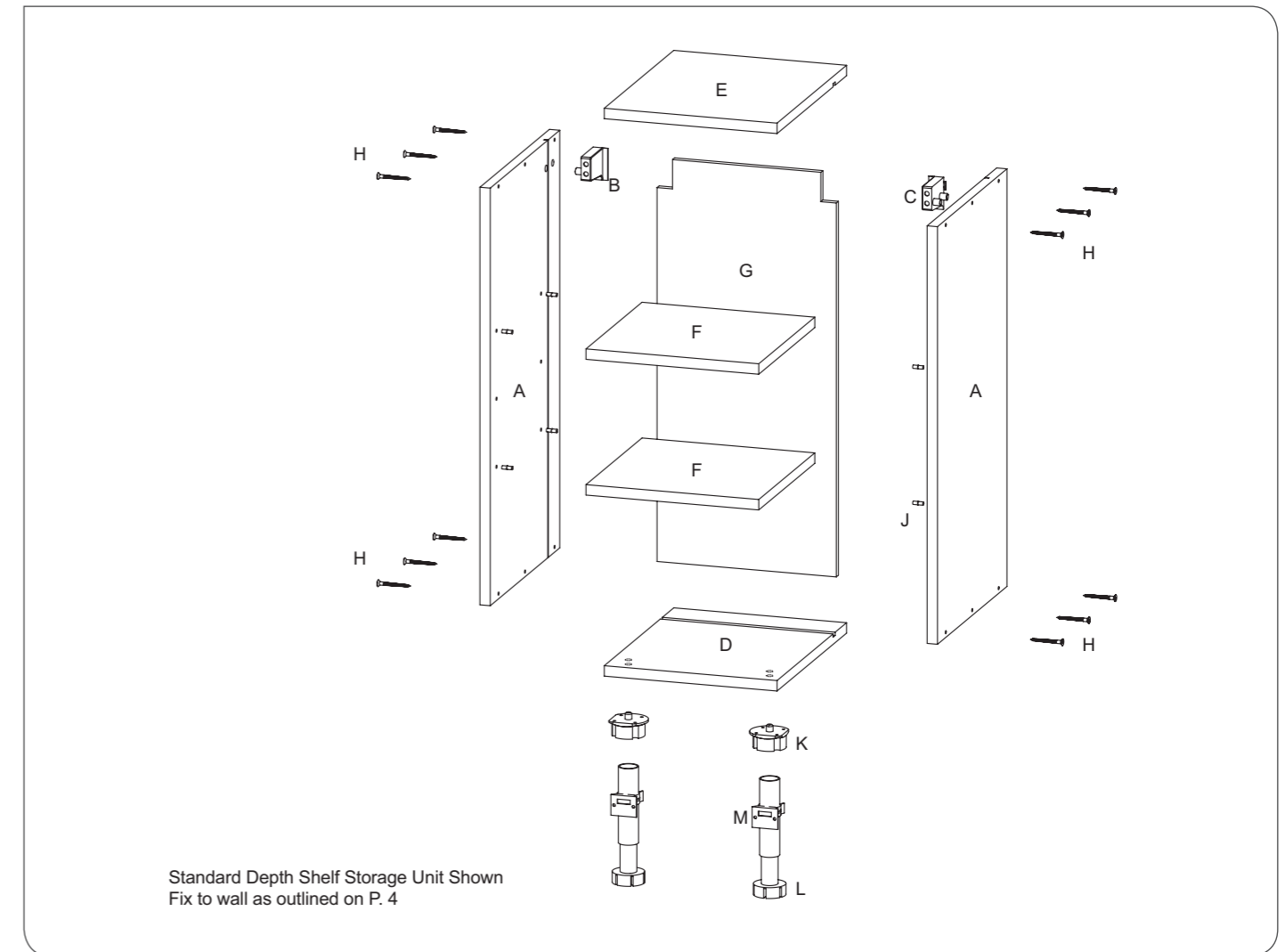

Pull Out Linen Bin Kit

The pull out linen bin kit is compatible with 300 Cupboards and inside the bottom of the 300 Full Height unit.

Secure the drawer runners into the pre-drilled pilot holes inside of the unit. On the hinge side, fasten the spacer blocks between the runner and the inside of the unit. Note that the door can be reversed depending on preference, so blocks will be on other runner in diagrams if door is hinged on the left hand side.

Once the runners are secured, fasten the door and then insert the Linen bin assembly onto the runners, tilting up slightly until the base locates into the runners.

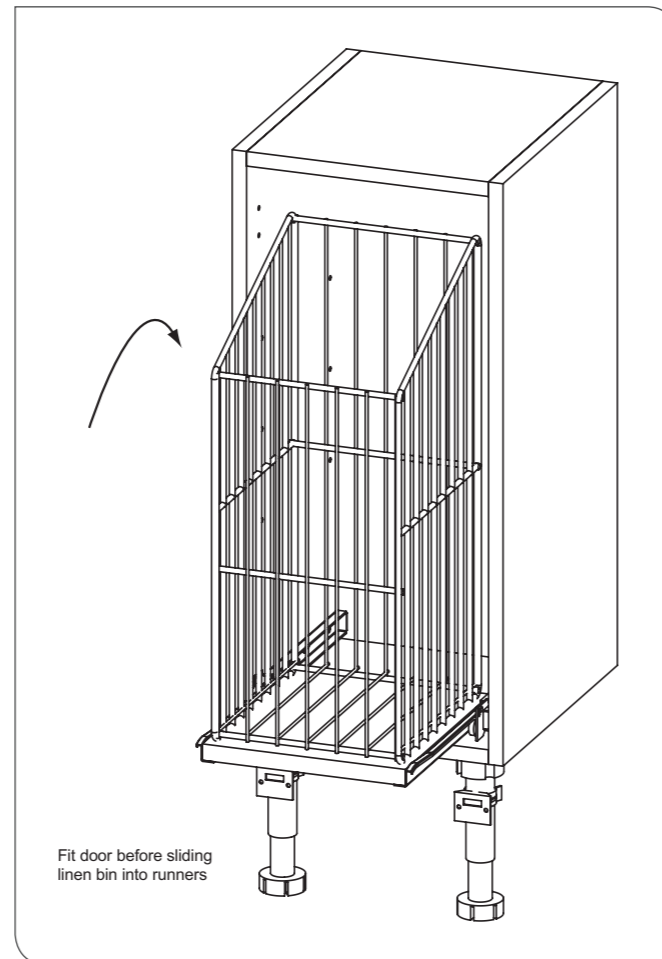
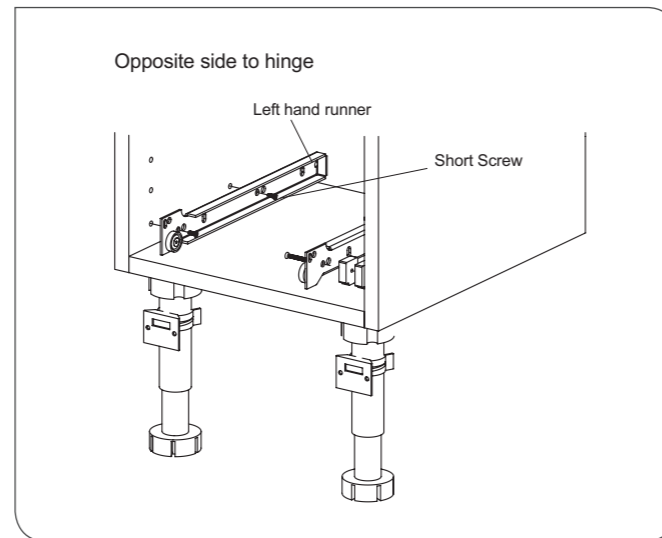

Mirror Display Shelf Unit

Glass Warnings: Do not strike glass components with hard or pointed items. Do not place very hot or very cold items against, or in close proximity to glass surfaces unless an adequately thick insulation material is used to prevent such items coming in contact with the glass.

The nominal thickness of the glass shelves is 8mm and is toughened for safety. The nominal thickness of the mirror glass is 3mm and is backed for safety.

If a glass component becomes chipped or broken, replace immediately. For details on replacement glass, contact Roper Rhodes customer services at the address below.

NOTE: The wall plugs supplied are only suitable for solid stone / brick walls. For plasterboard walls use specialist wall plugs.

Assembly.

1) Choose the hangers required for the installation in hand (if mounting next to a mirror for example, use the same hangers so that the shelf unit can be hung on the same plane as a neighbouring mirror). Hangers available are:

A) spacer hanging brackets (for use when the mirror is to be spaced approx 23mm off the wall – to create a void for a lighting transformer for example).

B) standard hanging brackets (concealed hangers that allow the unit to be spaced close to the wall)

2) Screw the necessary hardware to the back of the unit using the 15mm long screws provided.

3) Turn the mirror over – insert the chrome shelf supports onto the backboard using the 15mm screws provided. Using a hand screw driver ensure that all the hangers are secured but do not over tighten. Check that the nylon grub screws are on the underside of the chrome shelf supports.

4) Insert the glass shelves, starting from the top first. Using a hand screw driver, securely tighten the nylon grub screws on the underside of the shelf supports, making sure that the shelves are secured.

5) Place the chosen hanger into the hanging loop (if applicable) and measure the vertical distance between the top of the mirror and the holes on the hanging bracket.

6) Position the hangers onto the wall at the correct height and spacing, then mark off holes and drill as necessary.

7) Fasten hangers to the wall using the wall plugs provided (for stone or brick walls only). For other wall types use appropriate wall plugs or fixings. If in doubt, consult an expert.

8) Hang the unit on to the hangers, checking that all is secure.

IMPORTANT: Note that these glass shelves are intended for ornamental use only. The maximum safe evenly distributed load for each shelf is 500grams.

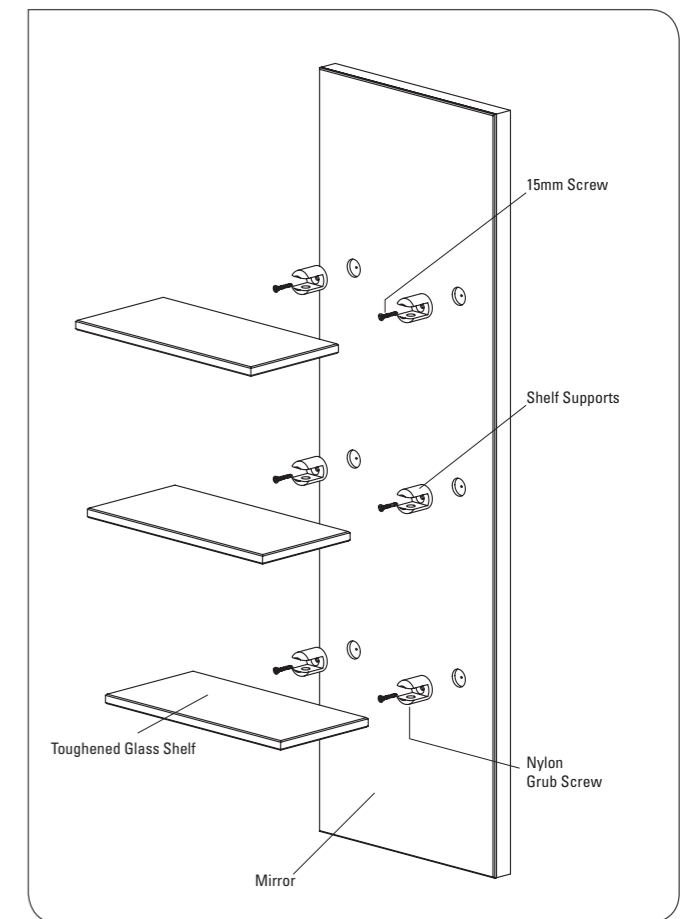
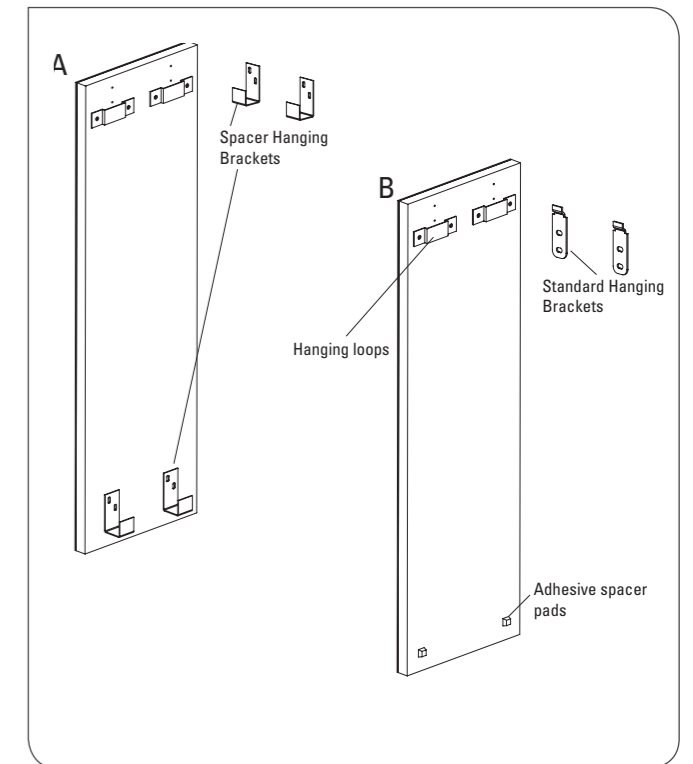

Mirrors & Glass Shelves

See the individual instructions supplied with each mirror for details on installation.

Glass Warnings: Do not strike glass components with hard or pointed items. Do not place very hot or very cold items against or in close proximity to glass surfaces unless an adequately thick insulation material is used to prevent such items coming in contact with the glass.

The nominal thickness of the mirror glass is 3mm and is backed for safety. Nominal thickness of cabinet/cupboard glass shelves is 3mm and shelves are toughened for safety (except shelves in 200mm wide units). Nominal thickness of mirror display shelf unit shelves is 8mm and are toughened for safety.

Never overload glass shelves. The maximum safe evenly distributed load for cabinet glass shelves is 3kg. The maximum safe evenly distributed load for 200mm cupboard glass shelves is 1kg. The maximum safe evenly distributed load for the glass shelves on the mirror display shelf unit is 500grams.

If a glass component becomes chipped or broken, replace immediately. For details on replacement glass, contact Roper Rhodes customer services at the address stated on these instructions. Always use the proper shelf supports as supplied with the unit.

Corner Posts / Configurations

Corner Spacer posts can be used in installations where units are required to go around a corner. Posts can be fastened to units either by drilling a suitable sized pilot hole from inside the carcass, or by using joiners blocks/angle brackets (not supplied).

Alternatively, if a larger void is present, filler panels can be used to create a corner as shown:

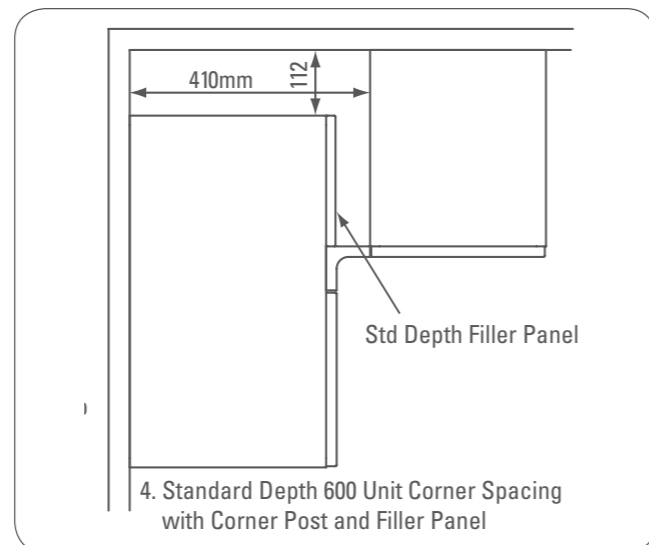
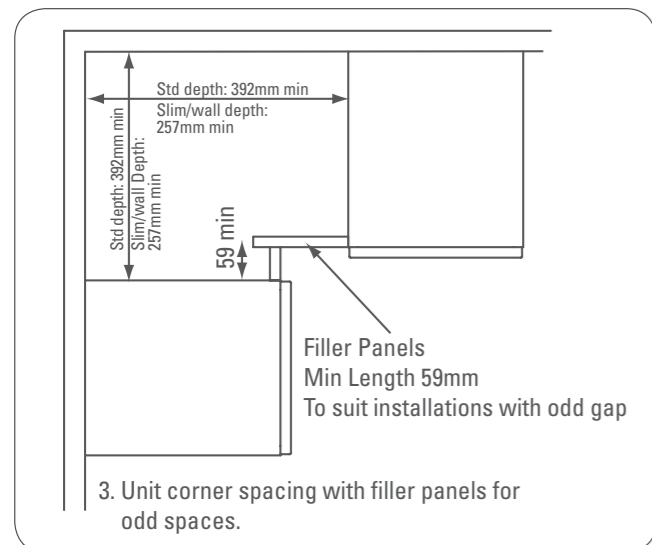
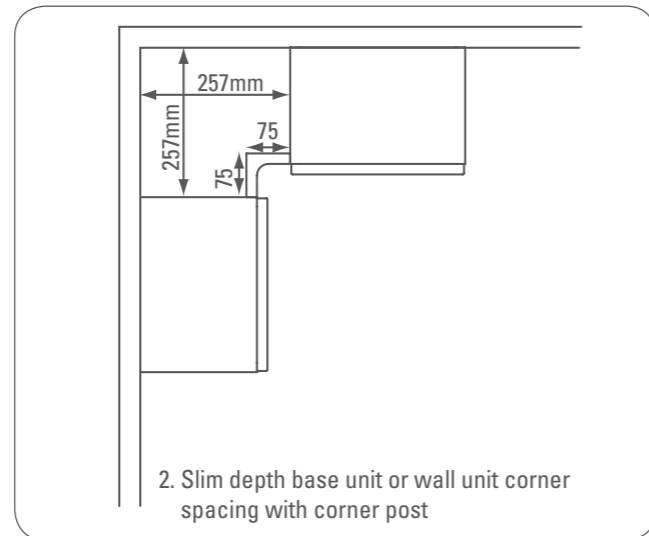
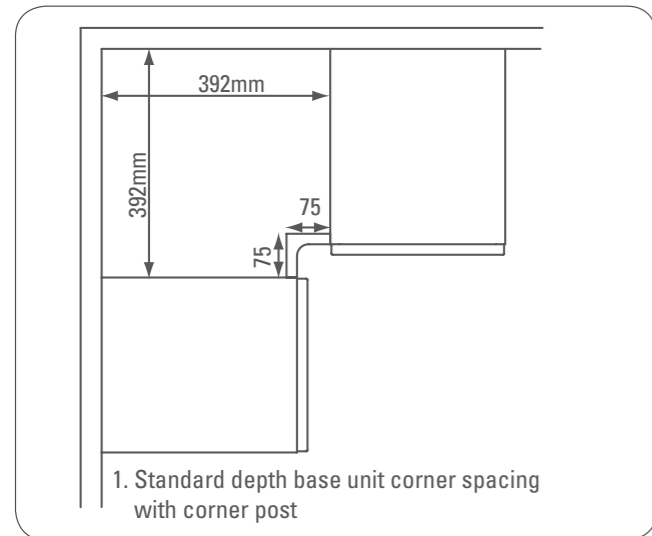

Filler Clad On End Panels

Filler panels (sometimes referred to as Fitter's panels) are available in 3 sizes – Standard Depth to be used if required next to a standard depth base unit, Slim Depth to be used next to a slim unit if required, and a Full Height Panel to be used next to tall height units if required.

Panels can be trimmed if filling a gap between a base unit and a return wall. Panels can also be scribed to the wall and clad the ends of units in installations where walls are not true. Secure panels by drilling a suitably sized pilot hole from inside the carcass, or by using joiners blocks/angle brackets (not supplied).

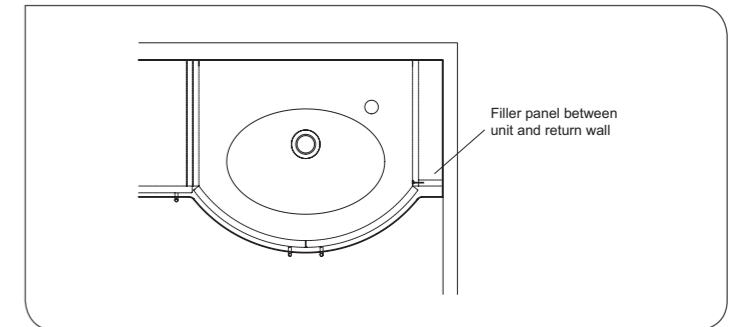

Design Panels

Design panels can be clad on to base units to give the furniture a framed appearance. Combining design panels with pelmets enables longer runs of units to take on a homogenous framed look by running the pelmet between the insides of design panels.

If a unit is wall hung, design panels can be cut to size – remember to allow for the height of pelmets if used. Cut using a fine toothed saw. All cut edges MUST be resealed with a suitable waterproof varnish, oil based paint or lacquer.

Design panels must be securely fastened to the base units. At least 4 screws must be used (not supplied) – drill suitable holes from inside the carcass and secure as necessary.

When a design panel is sited on to the floor, a clear bead of silicone must be used around the base to prevent any water ingress.

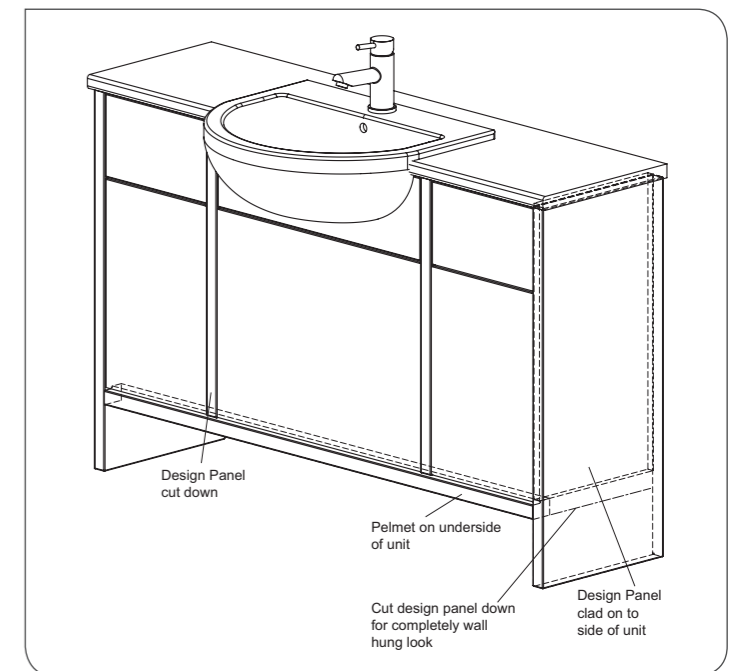

Pelmets

Pelmets can be used in conjunction with design panels (see above). They can also be used above a wall cabinet to form a cornice, or below a wall unit to form a lighting pelmet, allowing surface mounted down-lighters to be concealed.

The universal pelmets can be secured by either drilling through from inside the carcass and countersinking screws, or alternatively to use joiners blocks/angle brackets (not supplied) behind the pelmet.

Always drill suitably sized pilot holes for the hardware being used.

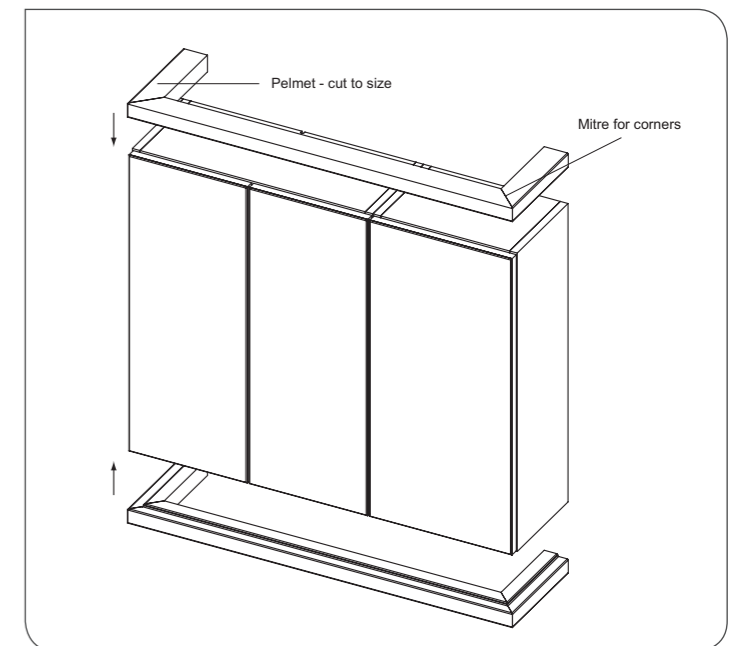

Plinth Fixing & Return Plinths

If using continuous plinths, these can be secured to the black legs on the base units using the clips supplied with the legs.

Snap off the mounting plate from the clip moulding, and screw to the back of the plinth using the screws provided, in the position that corresponds with the legs when the plinth is fitted.

Slide in the clip to the mounting plate and push the plinth into position onto the legs.

For return plinths, position the clip mounting plate such that it will not interfere with the clip of the front plinth that locates onto the same leg.

To support the plinth at the rear of the unit, secure the angle bracket supplied with the legs to the wall so that the plinth can not be pushed in under the unit.

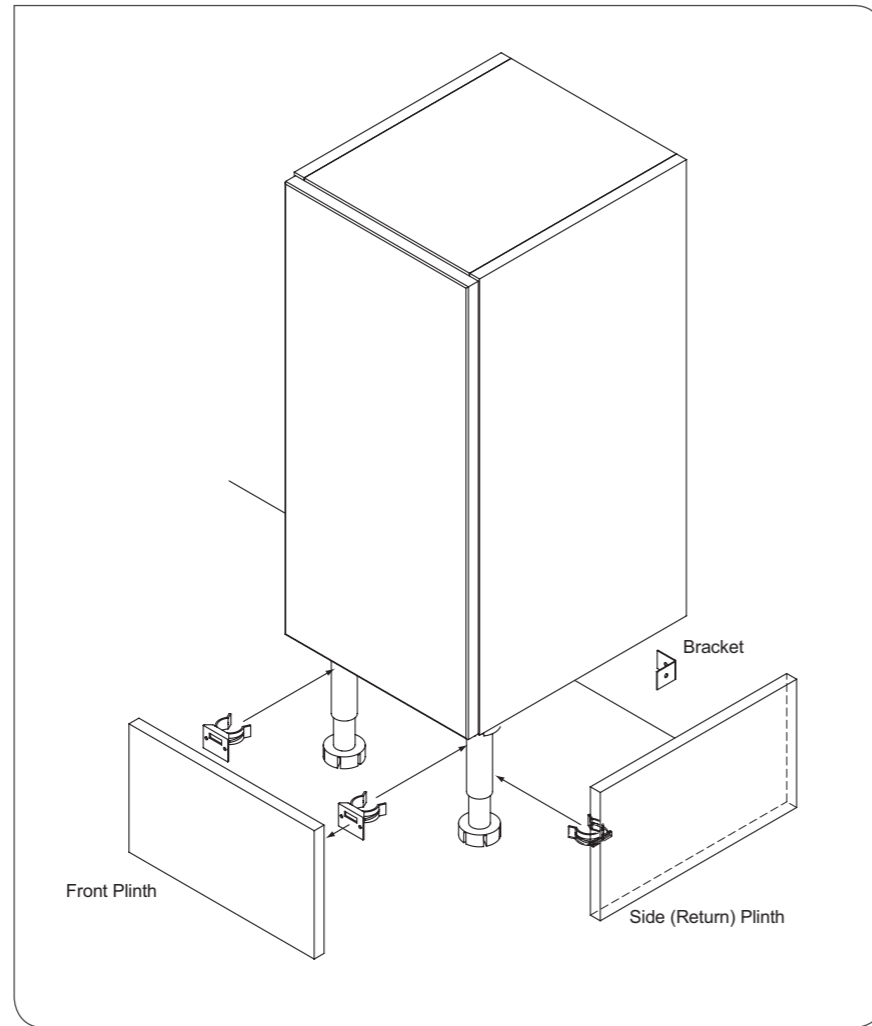

Bridging Panels

Bridging panels can be secured to the units underneath either by drilling and screwing up through from inside the unit or by drilling and screwing down from above the bridging panel. Use a hole cutter to cut holes for down-lighters as necessary. Alternatively, worktops turned upside down may also be used for fly-over applications. Fixings not supplied. Always make sure all flyovers are totally secure and that there is adequate clearance around lighting.

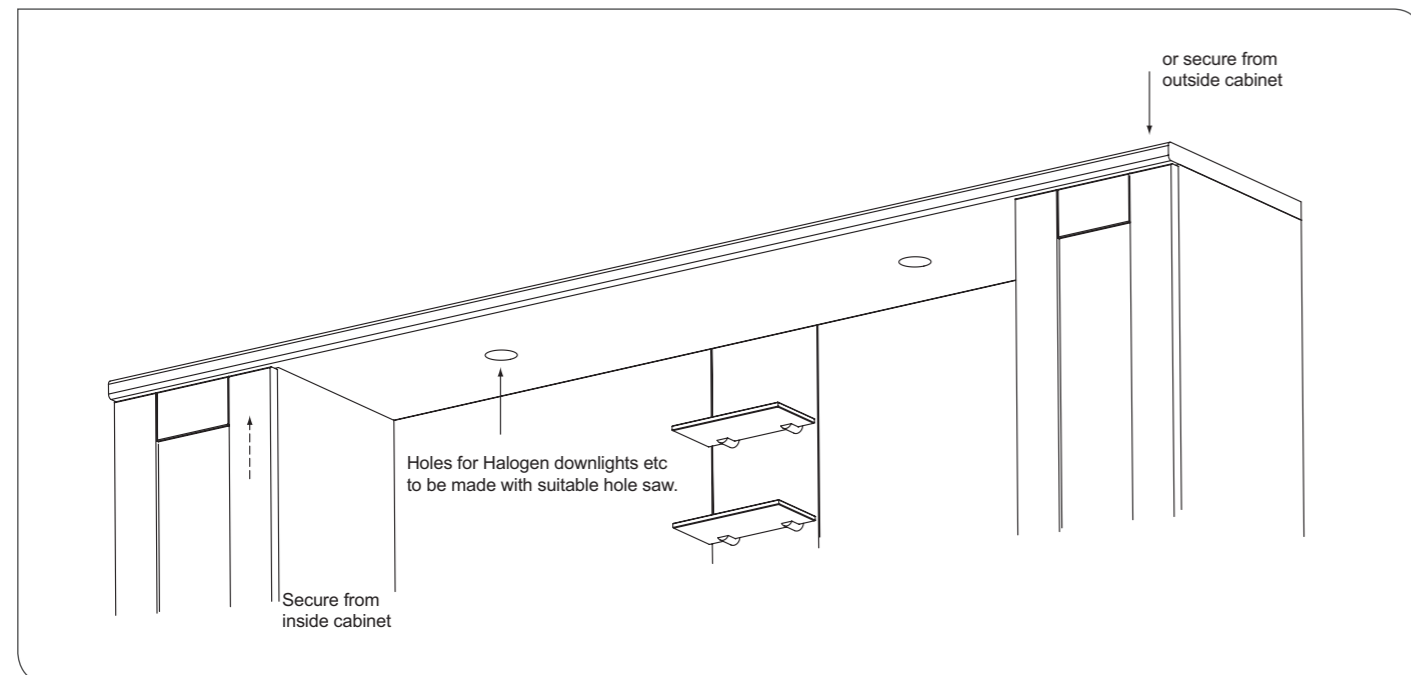

Door / Drawer Handles & Knobs

Doors are supplied un-drilled for handles/knobs so that the end user can create the exact look that they want to achieve by placing one of the many different sized handles or knobs in a variety of positions and/or orientations.

Once the handle/knob positions have been determined, mark off and place the door or drawer fascia on a flat piece of scrap wood. Use a sharp 5mm drill bit and drill from the front into the scrap wood on the reverse side of the door/drawer fascia.

With handles, use the template supplied with the handle to ensure that the correct hole spacing is achieved.

Always measure twice before drilling to make sure that the handles will be in the correct position. Check that hinges are not in the way of where handles will be drilled.

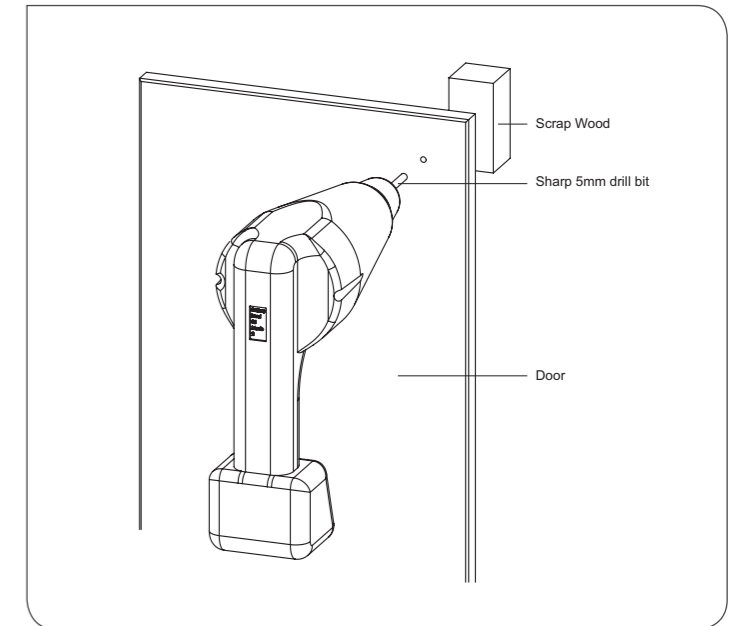

Lighting

All lighting and electrical fittings must be installed by a qualified electrician in accordance with the latest IEE wiring regulations. **Always read through the instructions supplied with each electrical fitting that is to be installed.**

Note that Mirror Wall Cabinets feature voids in which transformers can be located. Alternatively transformers can be located on the top of cabinets or flyovers. Transformers can also be located under units behind the plinths, as long as the plinth is secured with a screw to prevent inadvertent access.

Voids can be created behind mirrors using the supplied spacer brackets. See instructions supplied with mirrors for more details.

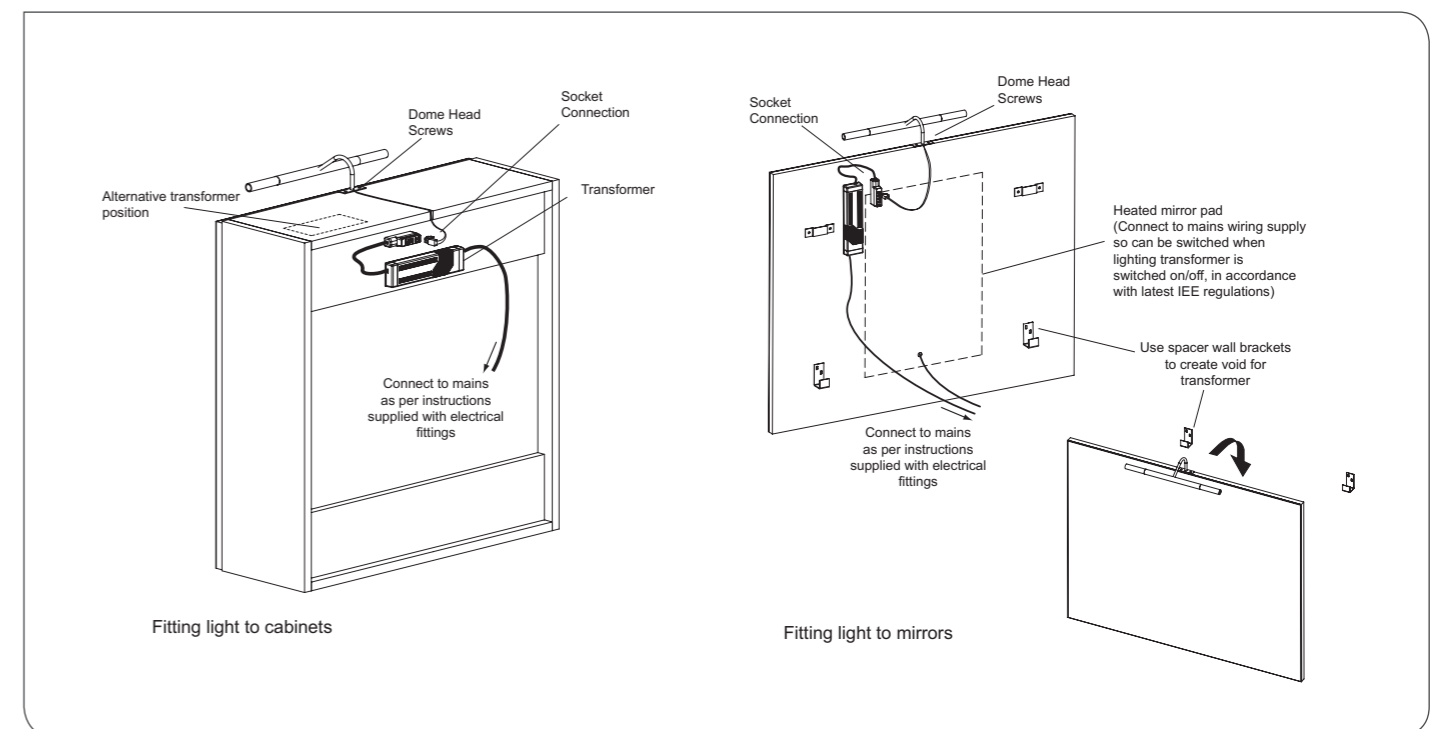

Care Instructions

By following the following guidelines, your Roper Rhodes Bathroom furniture will provide you with many years of service.

- Roper Rhodes bathroom furniture is designed for use within domestic installations that must be adequately ventilated. As with any timber product, bathroom furniture will be adversely affected if it is subjected to excessive moisture. It is strongly recommended that adequate bathroom extractor fans must be installed to prevent heavy condensation, to prevent damage to the furniture.
- All splashes and spillages MUST be mopped dry as soon as possible.
- After installation all sawdust must be removed with a vacuum cleaner. Drawer runners should be inspected and any dirt particles removed to promote a smooth running motion.
- Clean with a soft damp cloth and a mild soap solution if necessary. Test on an inconspicuous area first.
- Do not use chemical abrasive cleaners, bleaches or furniture polishes as the finish could be affected.