

CLOSE COUPLED PAN & CISTERN

FITTING INSTRUCTIONS

This product must be installed by a qualified fitter or plumber in accordance with and meet the requirements of the Water Supply (Water Fittings) Regulations 1999 and Scottish Byelaws 2004

INSTALLATION OF FLUSH VALVE

Turn the flush valve body anti-clockwise to part it from the flush valve seat

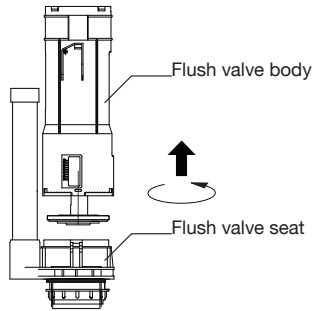

Install flush valve seat and seal as shown

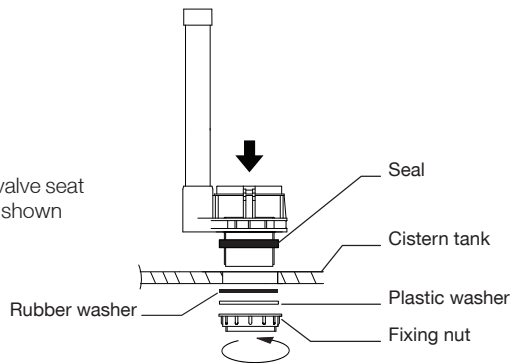

Insert flush valve body into flush valve seat, turn it clockwise until you hear a "click"

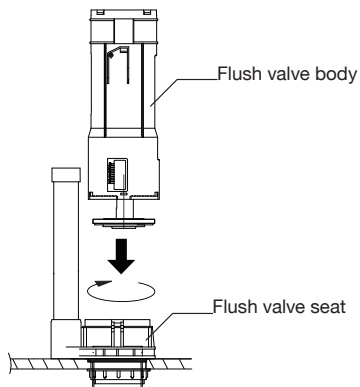

INSTALLATION OF FILL VALVE

Install the fill valve to the tank body using the rubber seal and plastic nut. Ensure the float cup has room to move up and down freely. The fill valve is pre-set to a height suitable for the cistern tank

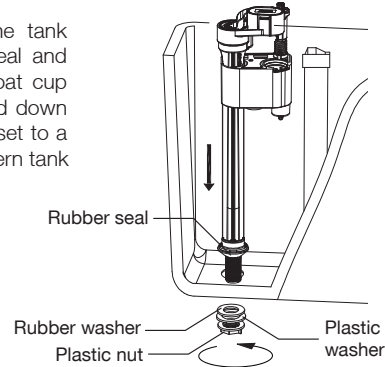

FILL VALVE ADJUSTMENT

The fill valve is factory set but if adjustment is required follow the instructions below.

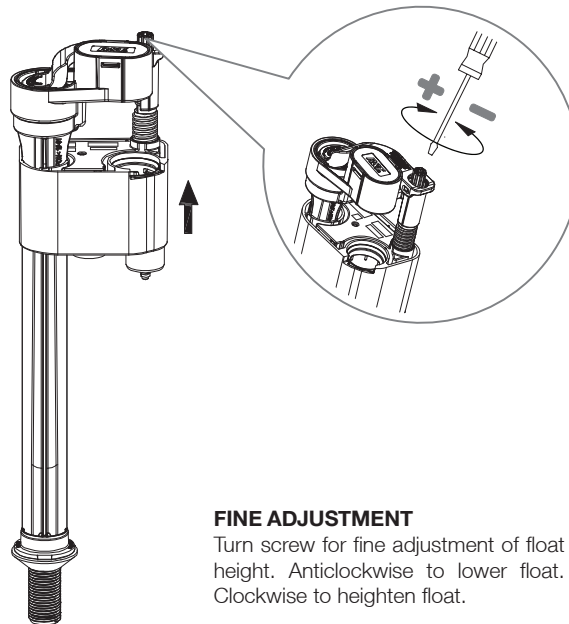

FLUSH VALVE ADJUSTMENT

The flush valve is factory set but if adjustment is required see diagrams below.

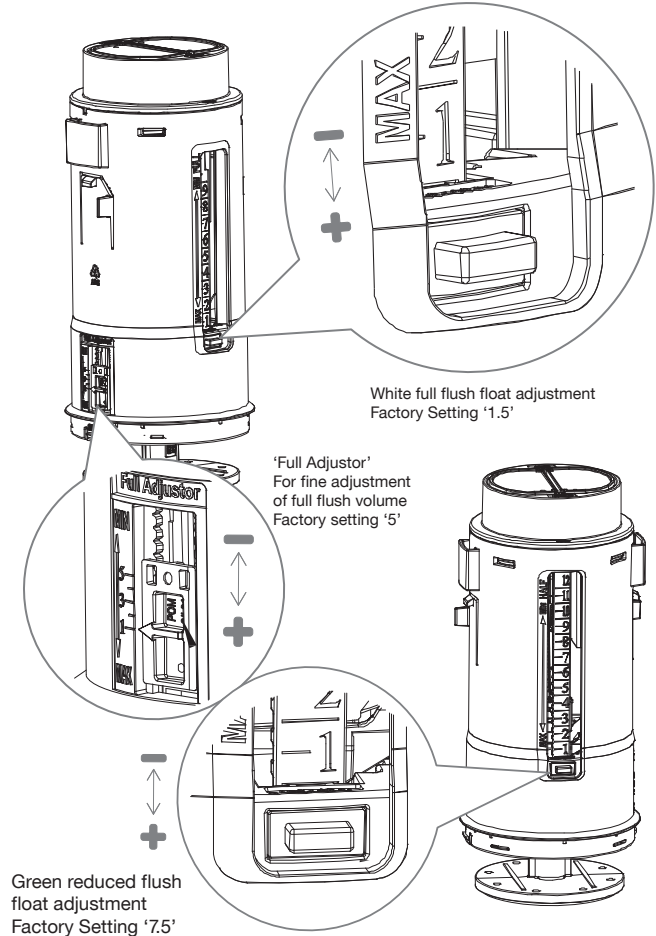

IMPORTANT

Flush out all impurities in the cistern prior to installation.

Cistern fittings are suitable for Water pressure: 0.2 - 8 bar

CLOSE COUPLED PAN & CISTERN

FITTING INSTRUCTIONS

This product must be installed by a qualified fitter or plumber in accordance with and meet the requirements of the Water Supply (Water Fittings) Regulations 1999 and Scottish Byelaws 2004

FITTING THE CISTERN TO THE TOILET PAN

With the flush valve and inlet valve fitted and adjusted the cistern tank can be fitted to the pan.

Fit the gasket around the flush valve outlet on the underside of the cistern.
When fitting the cistern to the pan take care to ensure the gasket is properly aligned in the gasket location. Failing to do so could result in leakage.

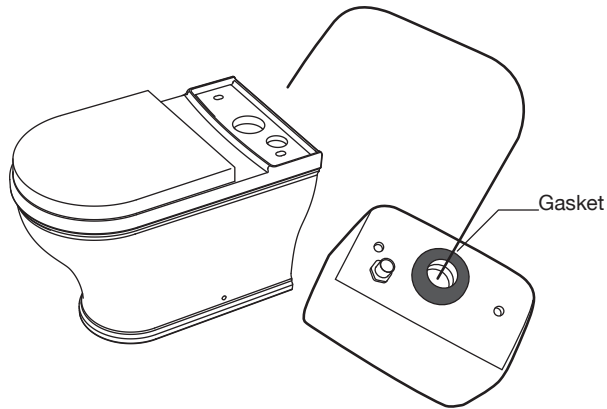

Insert the cistern fitting bolts arranging the components as shown in the diagram below.

Firmly tighten the nuts and wing nuts taking care not to overtighten as this could damage the ceramic.

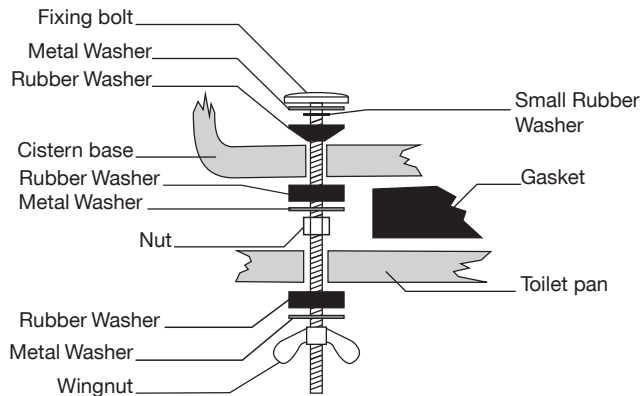

INSTALLING PUSH BUTTON

Fit the push button to the cistern lid using the plastic fixing nut.

Ensure the pins make contact with the flush buttons on the flush valve. To adjust the length of the rods turn the nut clockwise and anti-clockwise.

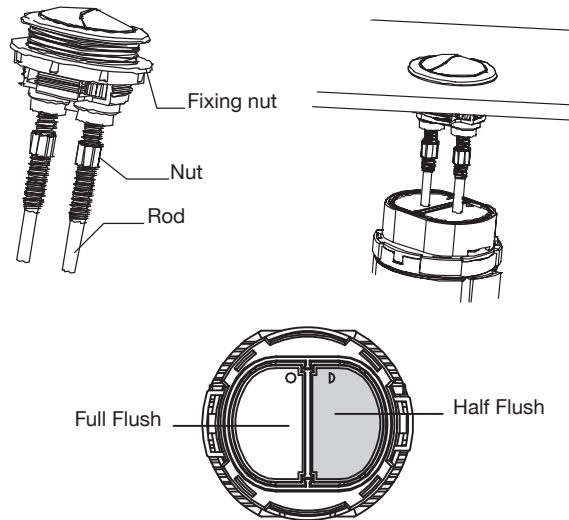

MAKING PLUMBING CONNECTIONS

Connect a new WC Pan waste connector and ensure it is adequately sealed around the toilet pan outlet to prevent leakage.

The inlet valve has a threaded connector. It is recommended that this thread is wrapped in PTFE tape before connecting the water supply. Do not overtighten the supply to the inlet valve as this could damage the inlet valve causing leakage.

Do NOT use silicone around gaskets or rubber seals as this will impair sealing of rubber components. After connecting the water supply to the inlet valve check that the inlet valve components do not touch the internal walls of the cistern and the float can move freely up and down.

Check all connections are secure and a soil pipe is fitted before testing the flush.

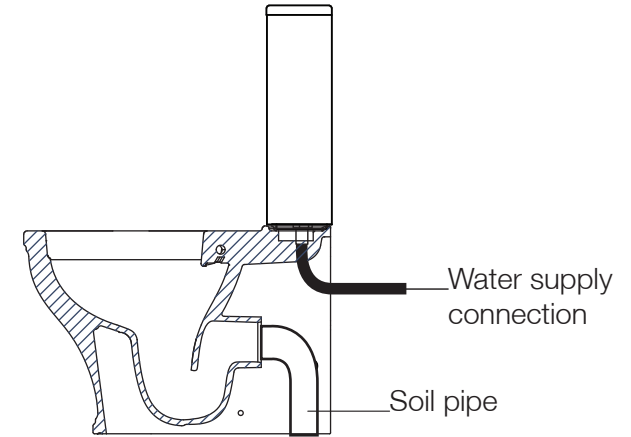

CONNECTION TO WATER SUPPLY

Connect the water supply to the cistern using an approved double check valve to fluid category 3 in addition to an accessible service valve.

OPERATION

Press the large button **once** for a large flush (6 litres factory setting)
Press the small button **once** for a small flush (4 litres factory setting)

CARE

DO NOT introduce caustic chemical substances (e.g. containing chlorine compounds or similar). These can damage the valve components and cause failure.

WATER LEVEL AND AIR GAP

It is important that there is a minimum air gap between the outlet of the fill valve and the top of the overflow of 30mm.

Also, the water level in the tank must be between 25-32mm below overflow tube on the flush valve.