

Technical Data Sheet

PURE

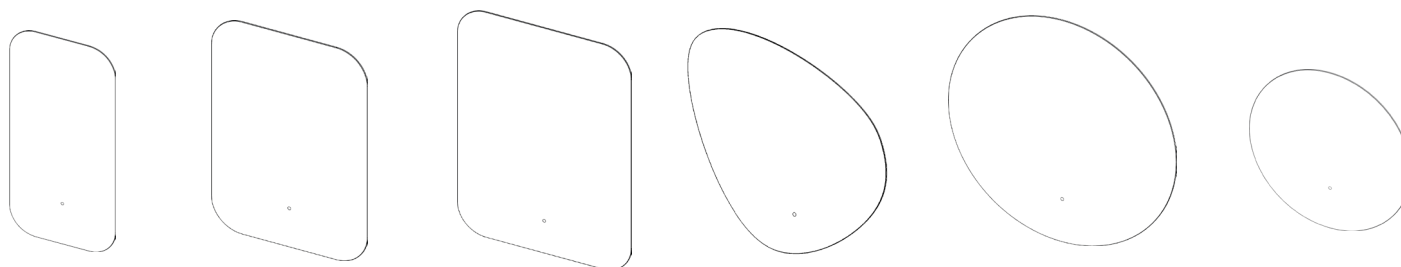

NOTE: Applicable only to batch numbers after PO4500029466. For batch numbers prior to this, please see “MIRRORS PURE TDS”

Box Contents:

Pure Mirror | Instructions booklet | Fixings – WFKMC-1

FAQ's:	Units	PRM040	PRM050	PRM060	PRM70B	PRM80C	PRM60C
Can the mirror be hung landscape?	-	Yes				No	
What is the thickness of the mirror glass?	mm	4	4	4	4	4	4
Is the mirror IP44 rated?	-	Yes – Suitable for use in bathroom zone 2					
What size fuse should I use?	-	Seek the advice of an electrician					
Where is the IR sensor/rocker switch located?	-	Front Centre Bottom					
Can the LED lighting be replaced?	-	No**					
Can the IR sensor be replaced?	-	Yes					
How do I turn on the demister pad?	-	The demister pad will turn on when the LEDs are turned on.					
Are illuminated mirrors supplied with mains cable?	-	All illuminated mirrors are supplied with a removeable 500mm mains cable. There is ample storage for excess cable in the back of the unit.					

5 Year Guarantee

We have complete confidence in this R2 bathroom Mirror and as such it is offered with a 5-year guarantee against defects in manufacture. The electronics are covered by our 2-year guarantee. In the unlikely event that this product should fail during the guarantee period we will either replace the faulty part or the complete unit as appropriate.

Dimensions are subject to change; customers are advised to measure actual product before commencing installation.

Fixing point dimensions are for guidance only/the positions of wall fixing must be checked when product is received.

*The Lumen represents the output of the LED. This may vary depending on the diffuser material i.e., glass or acrylic.

**The LEDs are not replaceable to maintain the integrity of the product's resistance to moisture ingress

***All wattage values have a tolerance of +/- 10%

ELECTRICAL SPECIFICATION

	Input Voltage	Lamp Type	Total Wattage (LED & Demist)***	Demist (W)***	Demist Size (mm)	LEDs (W)***	LED (lm)*	Energy Rating	CCT (K)	CRI	IP Rating	Electrical Class
PRM040	220-240V 50Hz	12V DC LED Lamp	32.4	11.9	220 x 270	20.5	2535	E	3000-6000	90+	IP44	Class II
PRM050	220-240V 50Hz	12V DC LED Lamp	38.5	18.0	300 x 300	20.5	2535	E	3000-6000	90+	IP44	Class II
PRM060	220-240V 50Hz	12V DC LED Lamp	42.7	18.0	300 x 300	24.7	3055	E	3000-6000	90+	IP44	Class II
PRM60C	220-240V 50Hz	12V DC LED Lamp	25.8	10.6	∅260	15.2	1885	E	3000-6000	90+	IP44	Class II
PRM80C	220-240V 50Hz	12V DC LED Lamp	44.7	22.7	∅380	22.1	2730	E	3000-6000	90+	IP44	Class II
PRM70B	220-240V 50Hz	12V DC LED Lamp	34.5	13.5	∅280	21	2304	F	3000-6500	80	IP44	Class II

TECHNICAL DRAWINGS

When hanging the mirror, please measure the distance between the fixing points.

PRM040

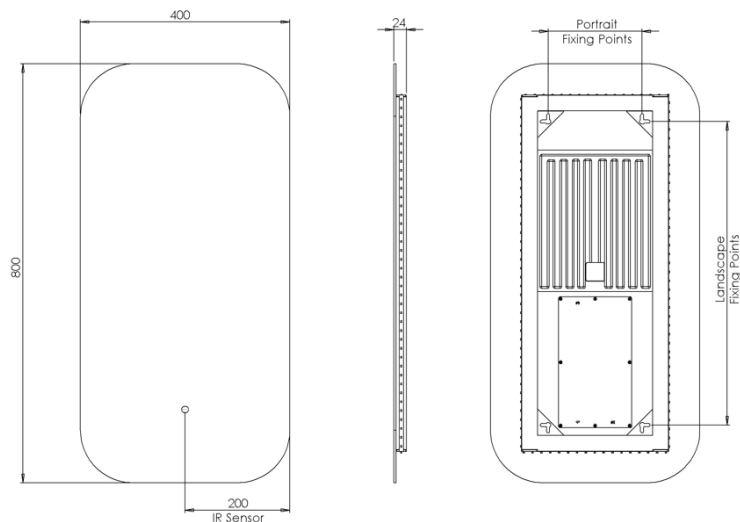

PRM050

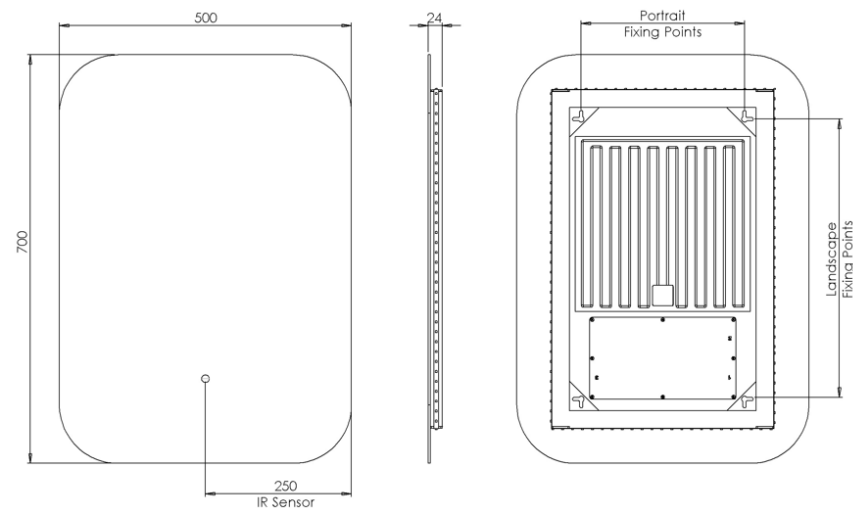

PRM060

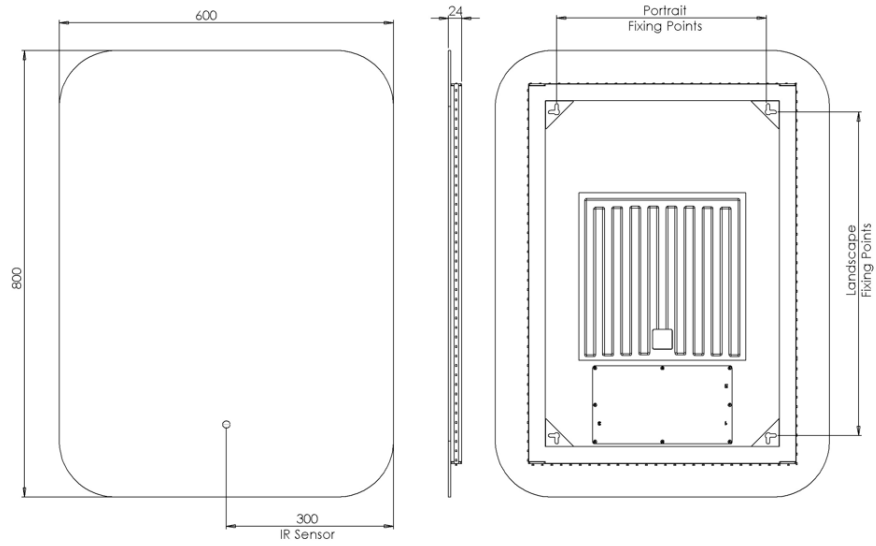

PRM60C

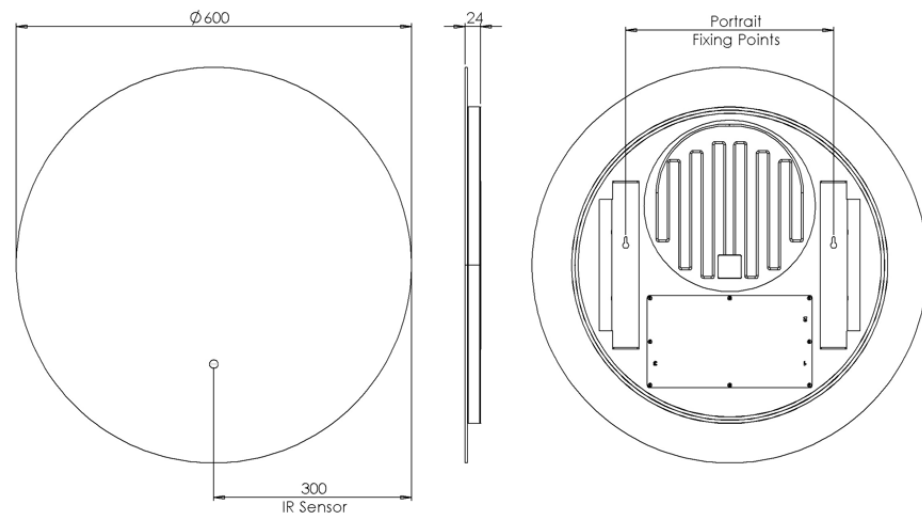

PRM80C

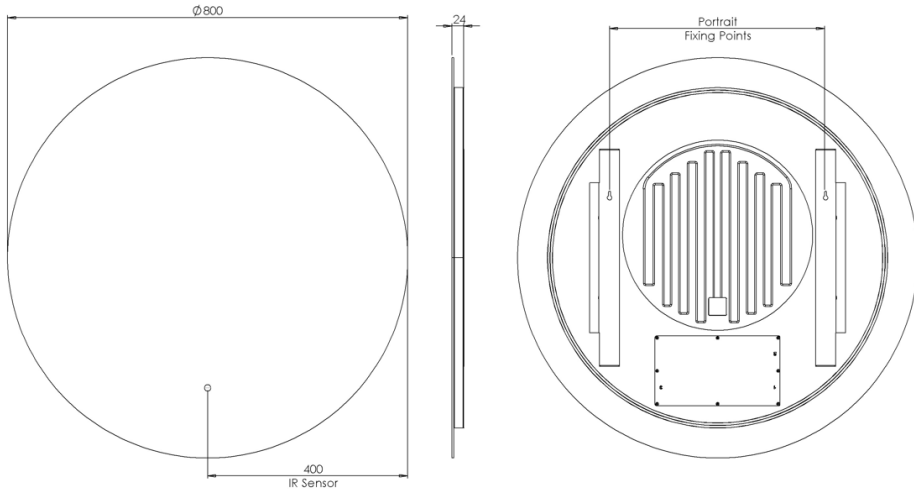

PRM70B – Orientation A

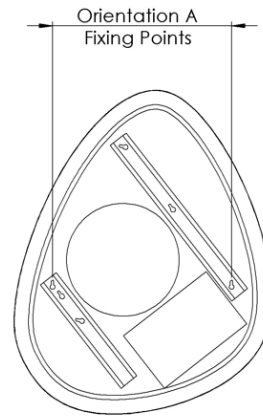
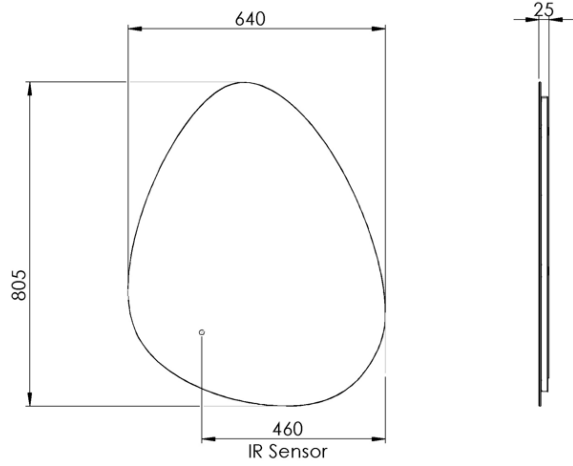

PRM70B – Orientation B

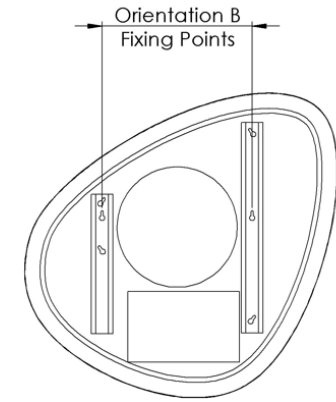
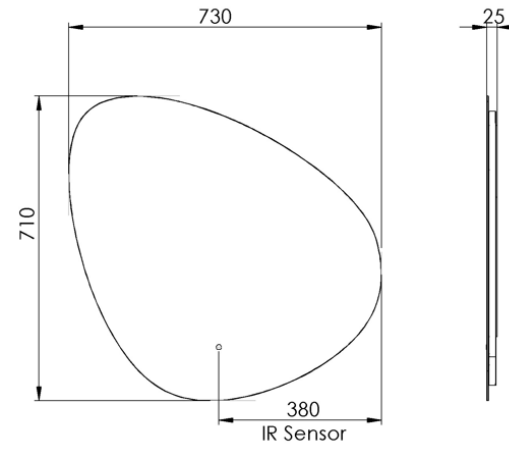

PRM70B – Orientation C

