

Technical Data Sheet

ROPER RHODES[®]

Motif STD Semi-Countertop Basin and Worktop

Whats in the box: 1x MTF3BAS.X, 1x White Overflow Trim, 1x Back Overflow Trim

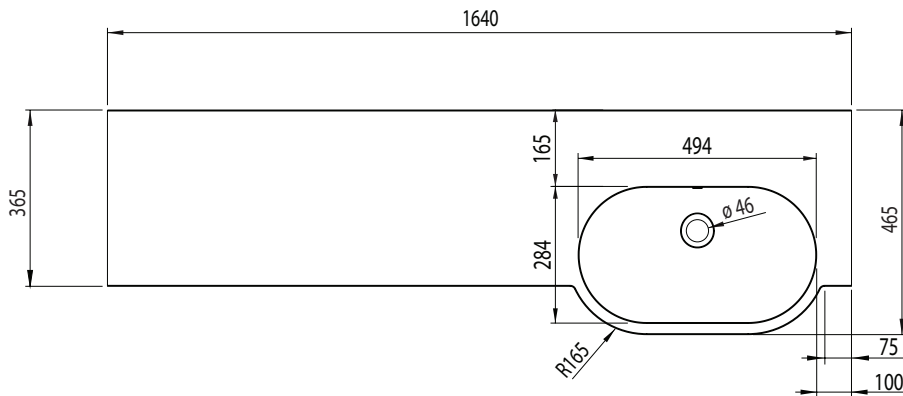

*Right Hand Basin Shown. Left Hand, Exactly the same dimensions, but reversed.

For Taphole *SEE INSTRUCTIONS*

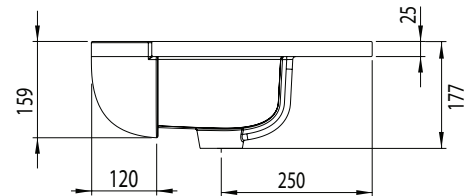

Diagrams not to scale
All dimensions in mm
tolerance of +/-5mm

Materials

Basin: Solid Surface

**Dimensions are subject to change, customers are advised to measure actual product before commencing installation.

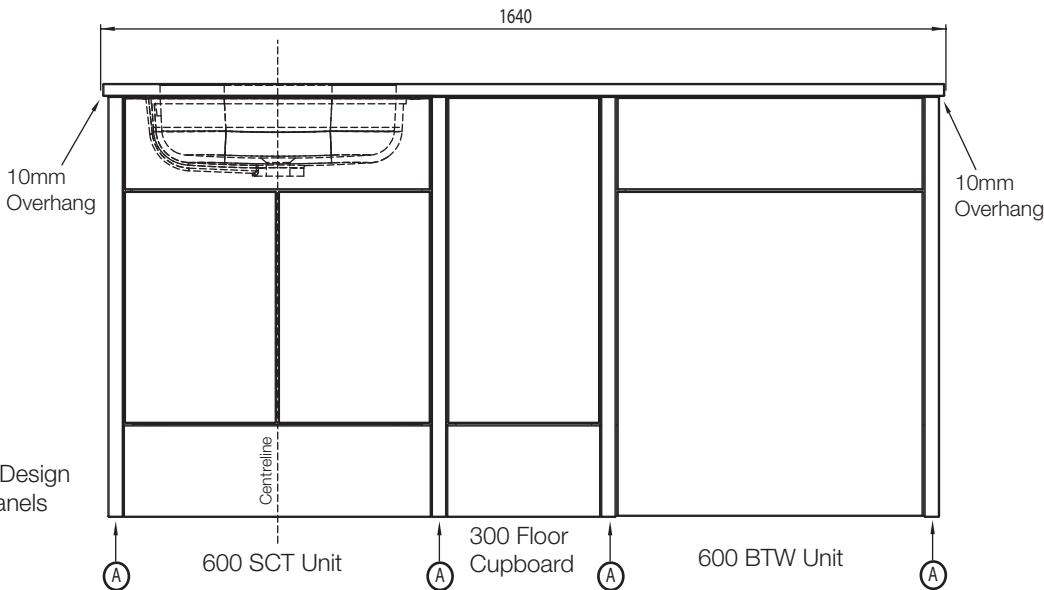

Note:

- 1640mm Motif Basin product can be used straight out of box on a run that consists of the below without needing to be cut to length:
4 x 30mm Design Filler Panels
1 x 600 SCT Unit
1 x 300 Floor Cupboard Unit
1 x 600 BTW unit

- Using this configuration leaves 10mm basin overhang to prevent water damage to furniture.

Note:

- 1640mm Motif Basin can only be used with a Standard Depth 600mm Semi Counter Top Unit.

Note:

- Basin waste hole is to be positioned in the centre of the 600 SCT Unit.

Solid Surface Information

Has many names including:

- Corian
- LG Hi-macs

A homogenous compound mixture of polyester and aluminium trihydrate (derived from a natural Bauxite ore). Basically the same material all the way through so can be cut and sanded back to perfect finishes. Aluminium trihydrate is Moulded, vacuum treated and then finished by hand to create a perfectly smooth matt finish which is highly dimensionally accurate. Can be sanded and refinished should any stains occur due to misuse. Can be patch repaired by simple sanding back since material is homogenous (same all the way through).

Material Benefits:

- Point impacts (255g ball dropped from 610mm)
- Stain resistant
- Colourfast
- Temperature resistance

Technical Data Sheet

ROPER RHODES®

Motif STD Semi-Countertop Basin and Worktop

Whats in the box: 1x MTF3BAS.X, 1x White Overflow Trim, 1x Back Overflow Trim

FAQs

- Q: What is the maximum water depth of the basin?
A: 90mm up to the overflow.
- Q: What is the width and length of the Basin Belly?
A: 519mm wide and projects 100mm from the worktop.
- Q: What is the depth of the Tapledge?
A: The Tapledge is 158mm deep.
- Q: Are there marks for taphole options.
A: No, see instructions & template.
- Q: Can you cut the worktop at either end of the bowl?
A: Yes, worktop can be cut to suit installation requirement with or without design and filler panels.
- Q: What configuration is the basin ready to be installed with?
A: Out of the box, it is ready to be installed with a 1500mm length run with 30mm end panels and a 10mm overhang each end.
- Q: What is the maximum run size for this basin?
A: 1500mm with 4 x 30mm filler panels.
- Q: Where do I position the basin on the carcass?
A: It is very important that the centre waste hole basin is in-line within the centre of the 600mm SCT unit. See illustration on Page 1
- Q: Can I use a 500mm SCT unit with this basin?
A: No, this is only suitable with a STD 600mm SCT Unit.
- Q: Is a basin overhang required?
A: It is recommended to have a basin overhang to prevent water damage to furniture. If using the 1500mm with 4 design filler panel configuration without cutting worktop, there is a 10mm basin overhang on both left and right hand of basin. See illustration on Page 1.

Note: Care should be taken when calculating configurations without filler panels.