

Technical Data Sheet

Quantum Dual Function Concealed Shower System

SQT1611 (Chrome), SQT1612 (Black), SQT1613 (Brass), SQT1624 (Gunmetal)

TAVISTOCK

Description

Code

Quantum 2F Concealed Shower System with Riser

SQT1611, SQT1612, SQT1613, SQT1624



Inlet Pressure	Flow Rate (l/min)
1bar	11.6
2bar	17
3bar	21

FLOW RATE DATA IS TESTED UNDER LABORATORY CONDITIONS: ACTUAL FLOW RATE MAY VARY DEPENDING ON DOMESTIC SUPPLY AND ACCESSORIES.

Dimensions

Diagrams not to scale. All dimensions in mm (tolerance of +/-5mm)

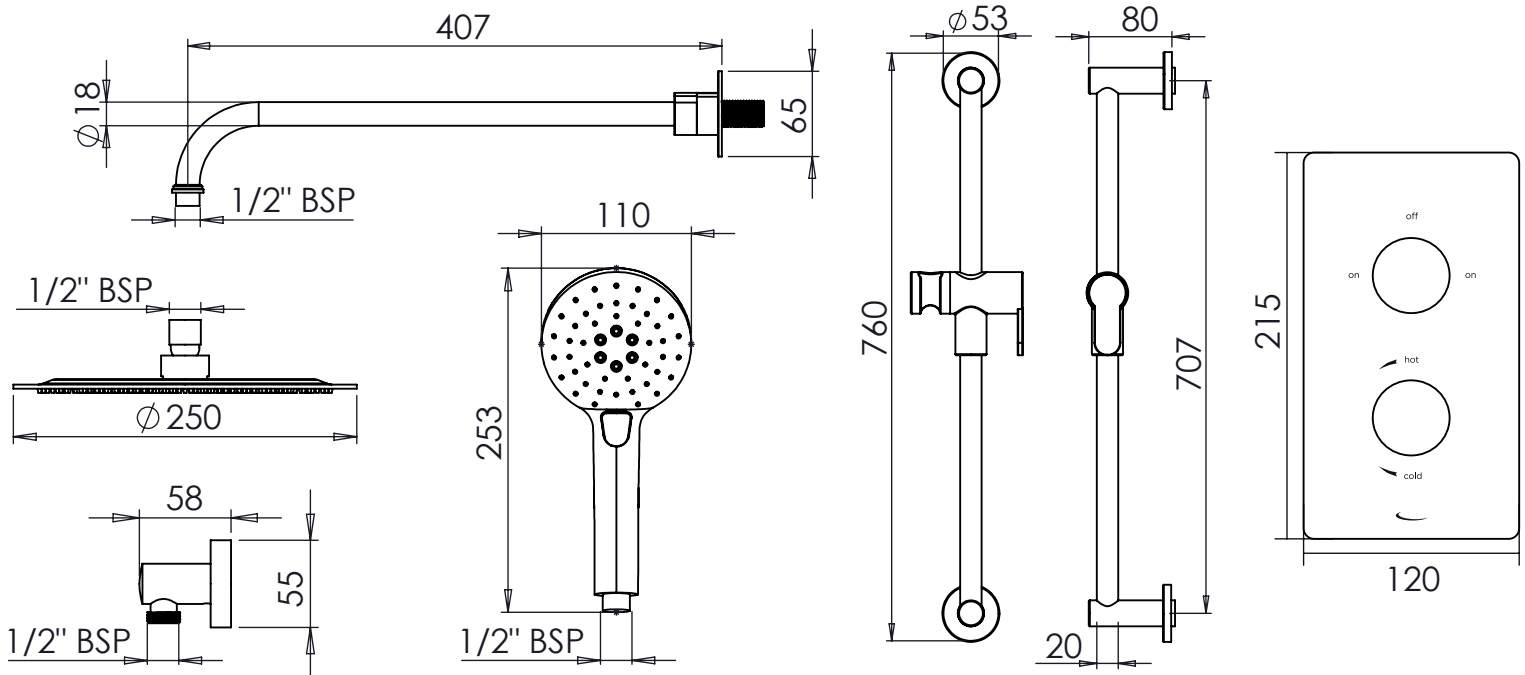

FAQs

What is the size of the connections? The valve uses 1/2" connections.

Can I have both shower options on at the same time? No

What size Pipework do I need? 15mm

Does the valve include isolation points? Yes

What is the recommended operating pressure? 1.0bar