

Technical Data Sheet

Regatta Shower Systems



No.	Description	Codes	Fixings Included
1	Regatta Concealed Dual Function Shower System with Shower Head and Handset	TR3013	YES



Inlet Pressure	Flow Rate (l/min)
0.5bar	8.00
1bar	9.00
2bar	13.50
3bar	17.50

Dimensions - TR3013

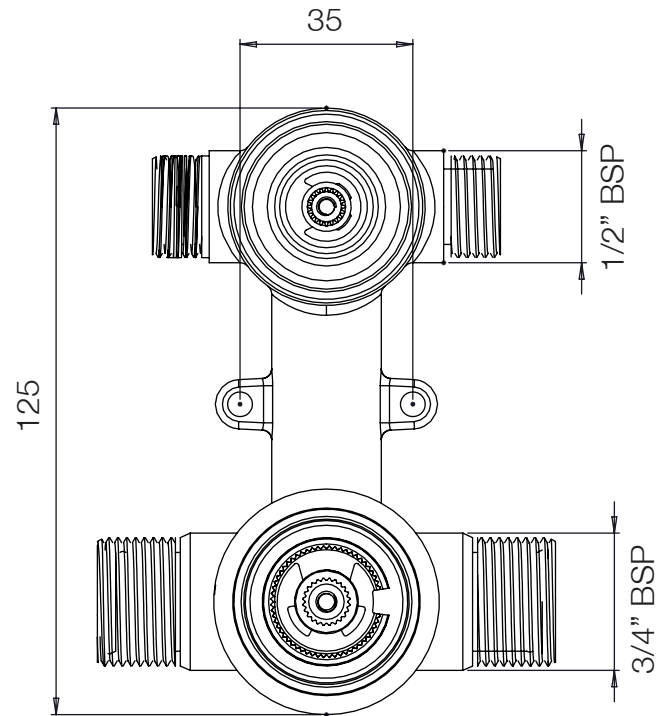
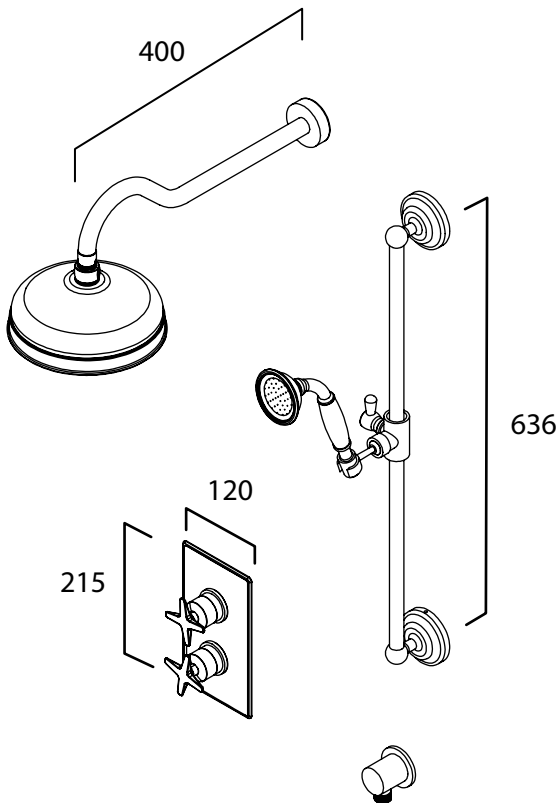

NOTE: VALVE TO BE RECESSED 80-100mm FROM FINISHED WALL SURFACE

FAQs

How tall is the riser rail? 636mm - the riser rail can be cut shorter if necessary

How long is the shower hose? 1.5m

What is the recommended minimum pressure for optimum performance of valve? 1.0bar

What is the valve connection size? 1/2" BSP for outlets / 3/4" BSP for inlets

What materials are the handles made from? Chrome-plated brass

Technical Data Sheet

Regatta Shower Systems



No.	Description	Code	Fixings Included
1	Regatta Exposed Dual Function Shower System with Shower Head and Handset	TR3015	YES



Inlet Pressure	Flow Rate (l/min)
1bar	10.29
2bar	13.98
3bar	17.34
4bar	19.98
5bar	22.56

Dimensions - TR3015

Diagrams not to scale. All dimensions in mm (tolerance of +/-5mm)

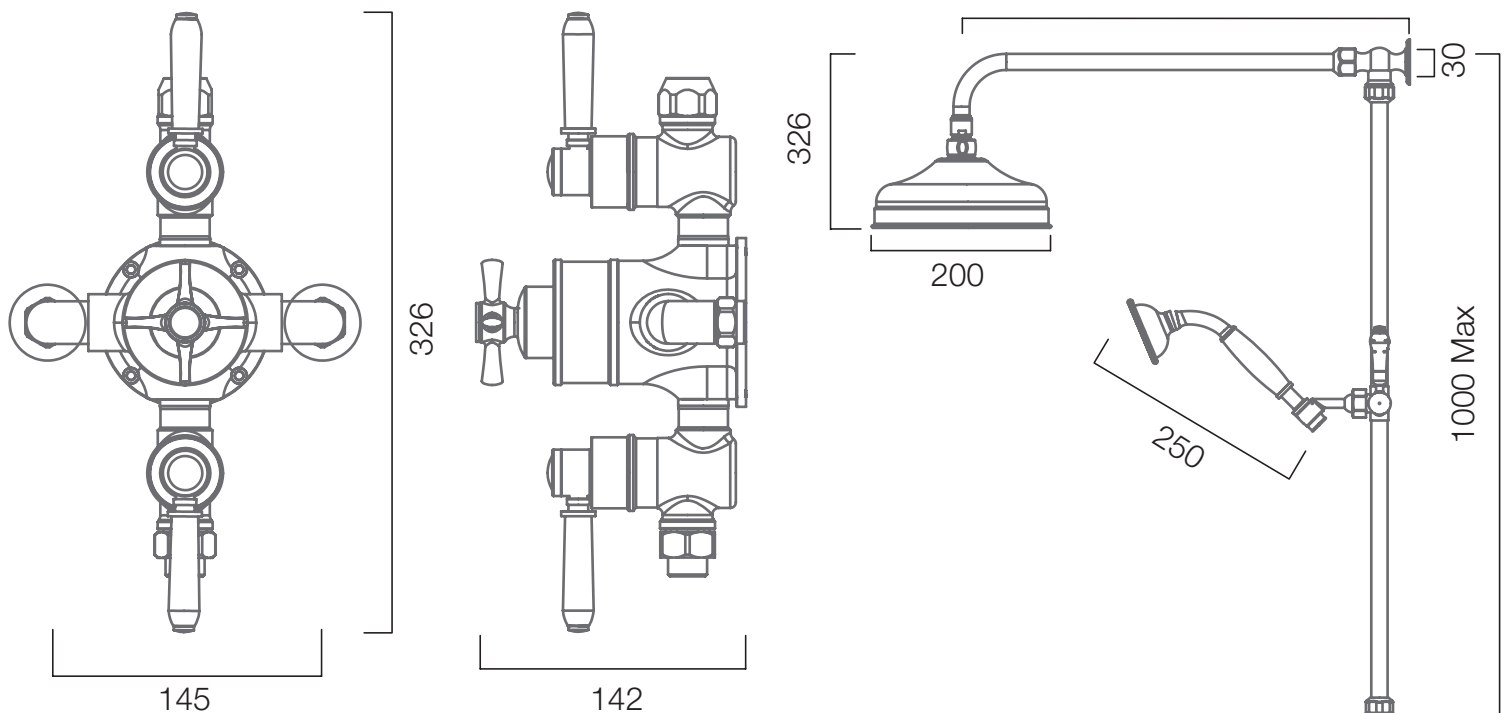

FAQs

How tall is the riser rail? 1000mm - this can be cut down if necessary

How long is the shower hose? 1.5m

What is the recommended minimum pressure for optimum performance of valve? 1.0bar

What is the valve connection size? 1/2" suitable for 15mm pipework

What materials are the handles made from? Chrome-plated brass