

THERMOSET SHOWER SEAT

Technical Data Sheet

ROPER RHODES

Features:

- Compact design - Ideal for shower cubicles
- Folds up flat to the wall when not in use
- Durable thermoset plastic design
- Chrome plated trim
- Easy to install
- Holds up to 160KG



Parts Checklist

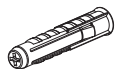

M10 Fischer SX
Nylon Wall Plug
x5



Stainless Steel
Washer
x5



M8 x 70mm
Stainless Steel
Coach Screw
x5

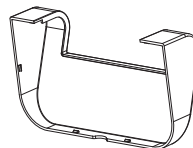

Chrome plated
bracket cover
x1

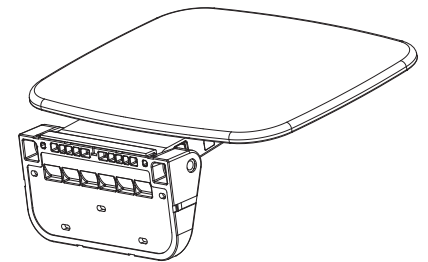

Shower Seat
Assembly
x1

Overall Dimensions

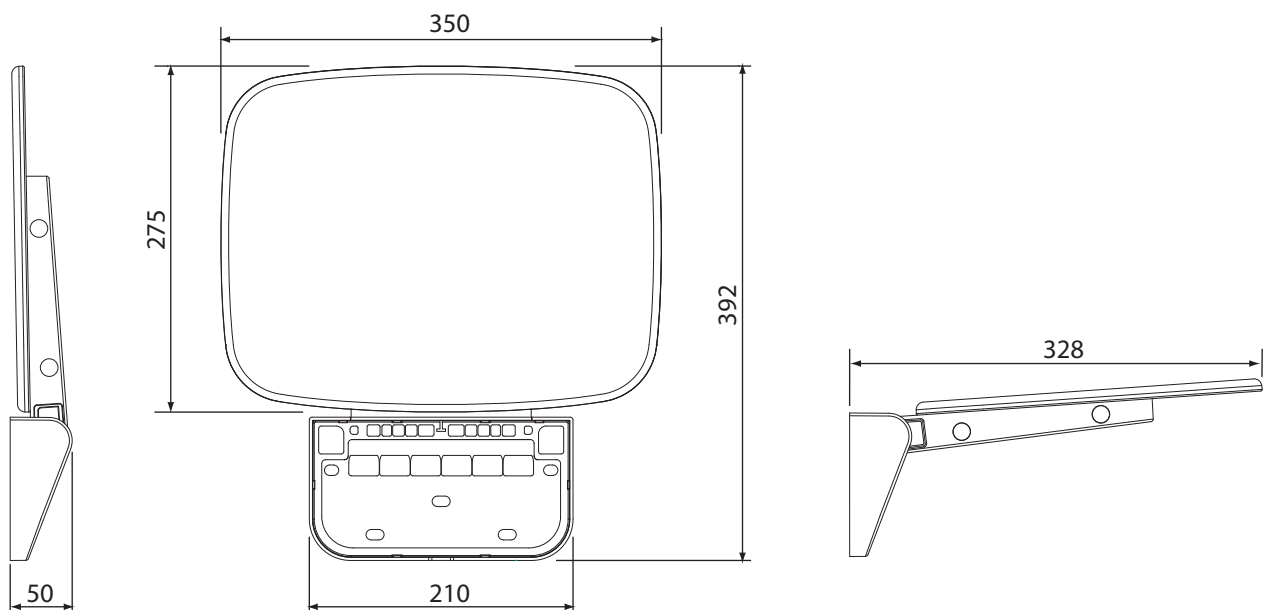

THERMOSET SHOWER SEAT

Technical Data Sheet

ROPER RHODES

Mounting Instructions

Stage 1

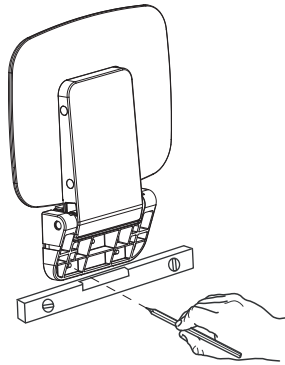

Apply masking tape at the desired fixing height on the wall tiles. Recommended seat height is 450mm +/- 50mm. Place the seat at the desired height and use a spirit level to ensure it is level. Mark off the fixing holes with a pencil.

Stage 2

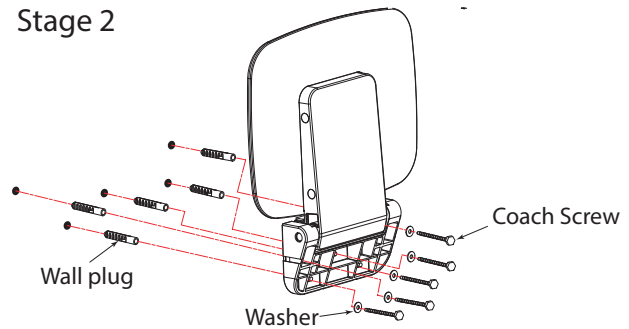

For solid brick/stone wall installations

Using a suitable 10mm bit, drill the five holes to a minimum depth of 70mm. Insert the wall plugs. Using a 13mm socket with extension arm, screw the seat to the wall using the coach screws and washers supplied.

For reinforced stud wall installations

Screws must fit into the studs or reinforced noggins of a stud wall installation. The complete area behind the seat must be suitably reinforced by the installer. Drill pilot holes into the reinforced area. Using a 13mm socket with extension arm, screw the seat to the wall using the coach screws and washers supplied.

Stage 3

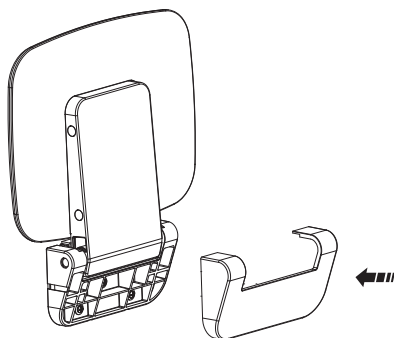

Check that the screws are fully tightened and the seat is securely fastened to the wall. Click the chrome bracket cover over the base of the shower seat to conceal the fittings.

Operation

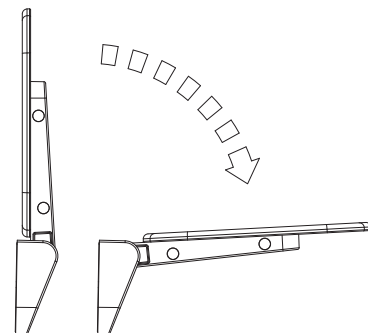

Pull the seat down for use. When finished gently fold the seat up against the wall to maximise space within your shower enclosure