

# Technical Data Sheet

# ROPER RHODES®

Recite 2F Concealed shower Valve CH - SV4006

No.	Description	Code	Fixings Included
1	Recite 2F Concealed shower Valve CH	SV4006	YES



Inlet Pressure	Flow Rate (l/min)
1bar	11.6
2bar	17
3bar	21

Flow from valve may vary depending on accessories and domestic supply.

## Dimensions - SV4006

Diagrams not to scale. All dimensions in mm (tolerance of +/-5mm)

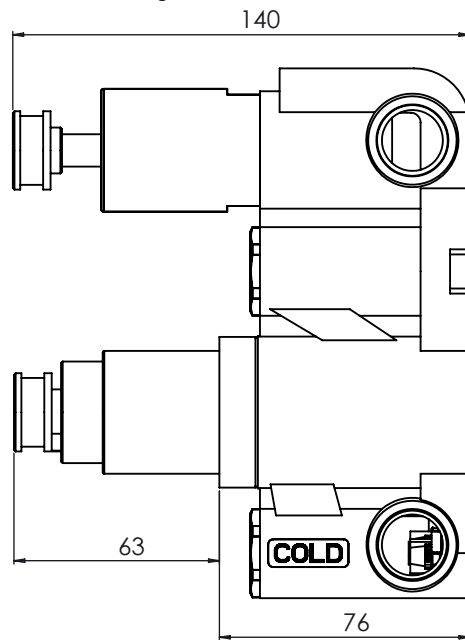
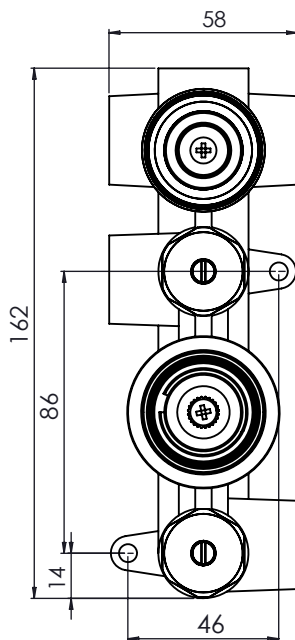

## FAQs

**What is included in the valve box?** The valve, a cover plate, a set of handles and trim rings.

**What is the size of the connections?** The valve uses 1/2" connections.

**What is the recommended operating pressure?** 1.0bar

## Components

Valve - RR18

Chrome Valve Plate - SVCOMP6

Chrome Valve Handle - SVHANREC

# Technical Data Sheet

# ROPER RHODES®

Recite 2F Concealed shower System CH - SVSET153

No.	Description	Code	Fixings Included
1	Recite 2F Concealed shower System CH	SVSET153	YES



Inlet Pressure	Flow Rate (l/min)
1bar	11.6
2bar	17
3bar	21

Flow from valve may vary depending on accessories and domestic supply.

## Dimensions - SVSET153

Diagrams not to scale. All dimensions in mm (tolerance of +/-5mm)

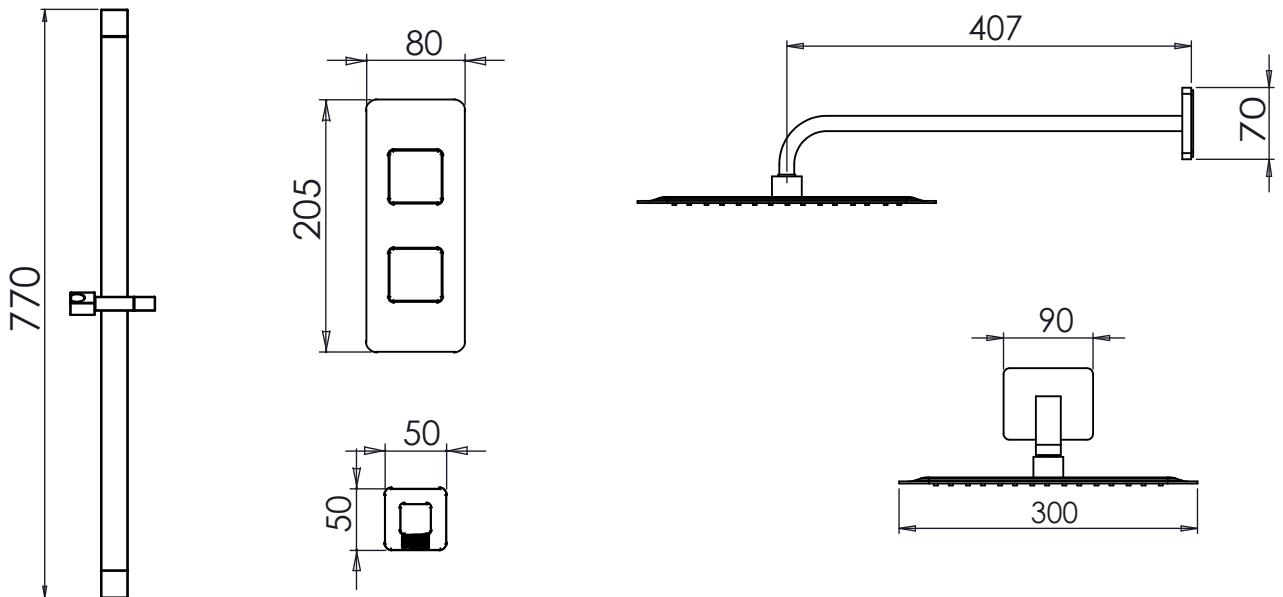

## FAQs

**What is the size of the connections?** The valve uses 1/2" connections.

**Can I have both shower options on at the same time?** Yes

**What size Pipework do i need?** 15mm

**Is it suitable for stud walls?** It is recommended you use CLS size 89mm depth within the wall

**Does the valve include isolation points?** Yes

**What is the recommended operating pressure?** 1.0bar

## Components

- Valve - RR18
- Chrome Shower Plate - SVCOMP6
- Chrome Valve Handle - SVHANREC
- Riser Rail - SVRAIL11
- Handset - SVHEAD45
- Easy Clean PVC shower Hose - SVHOSE02
- Brass Wall Elbow - SVACS06
- Fixed Arm - SVARM05
- Stainless Steel Shower Head - SVHEAD15