

# Technical Data Sheet

# ROPER RHODES®

## Wessex Shower Systems

No.	Description	Code	Fixings Included
1	Wessex Single Function Exposed Shower System	SVSET66	YES

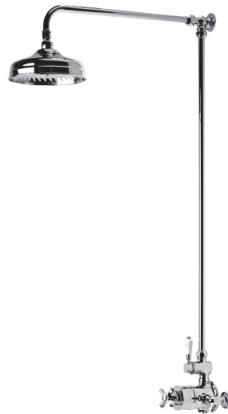

**FLOW RATE DATA IS TESTED UNDER LABORATORY CONDITIONS: ACTUAL FLOW RATE MAY VARY DEPENDING ON DOMESTIC SUPPLY AND ACCESSORIES**

Inlet Pressure	Flow Rate (l/min)
0.3bar	6.74
0.4bar	7.78
0.5bar	8.70
1bar	12.30
2bar	17.39
3bar	18.20

### Dimensions - SVSET66

Diagrams not to scale. All dimensions in mm (tolerance of +/-5mm)

\*Dimensions are subject to change, customers are advised to measure actual product before commencing installation.

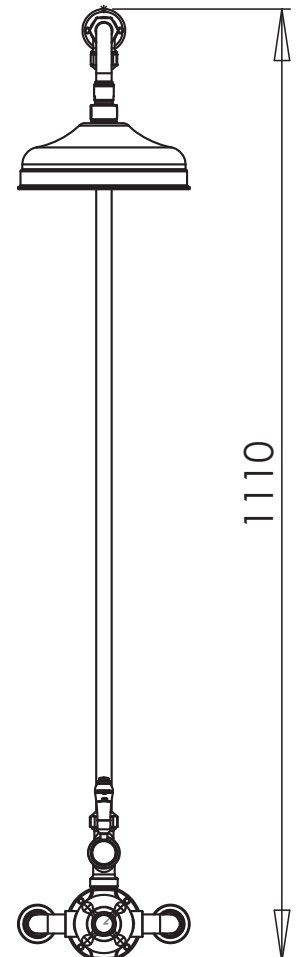
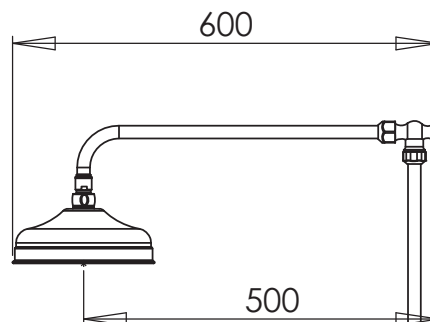
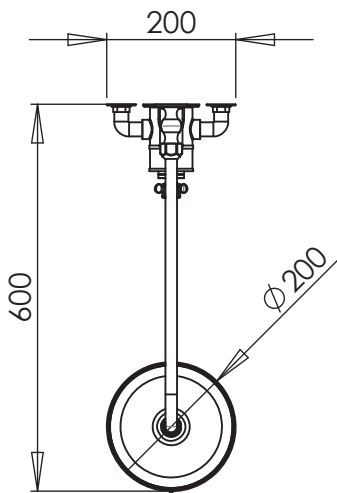

### FAQs

FAQ	Answer
Valve Inlet Dimension	1/2 Inch BSP
Adjustment Range of Riser Rail (once fixed to wall) and overhead.	Can be cut shorter
Hose Length	1.5m
What is the diameter of the riser rail?	18mm

