

Technical Data Sheet

ROPER RHODES®

SYSTEM 600mm Isocast Basin

Whats in the box: 1x SYS500IS + Overflow Kit

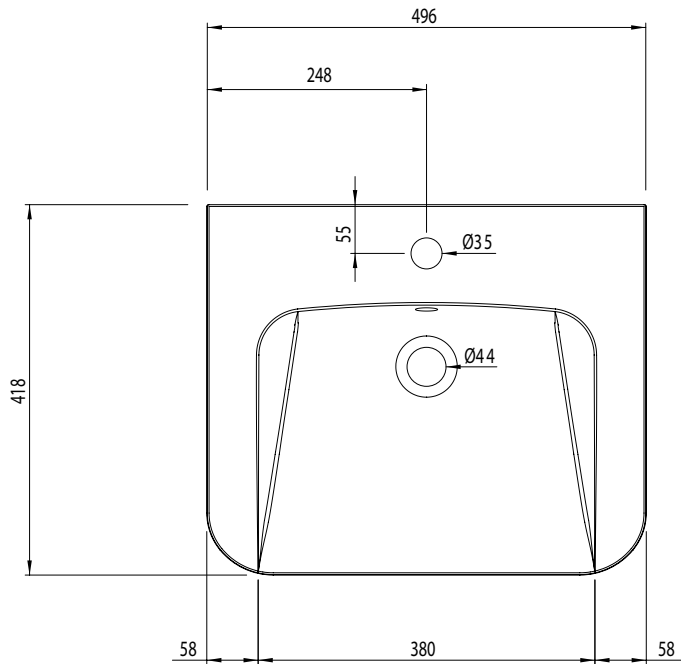

Diagrams not to scale
All dimensions in mm
tolerance of +/-5mm

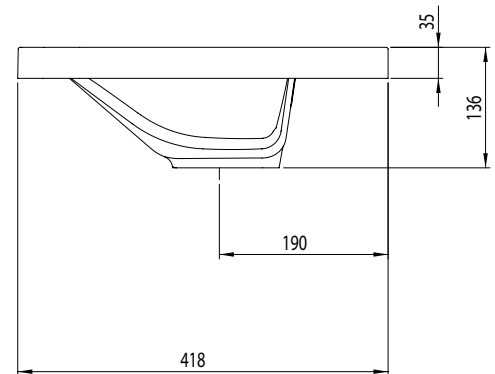

**Dimensions are subject to change, customers are advised to measure actual product before commencing installation.

Materials

Basin: Isocast (Gloss Finish)

Has many names including:

- Gelcoat
- Cultured marble
- Cast mineral marble
- Synthetic marble

Base material is 70% natural (aggregate dolomite rock - calcareous magnesium carbonate). A misconception is that this material is completely manmade. The other 30% is a mixture of various polyester resins. 1.5 - 2.0mm Top coating of "gelcoat" which is the proprietary name for the polyester resin used to seal all top faces of the basin / worktop. Tolerance of +3/-0mm. Ceramic is more typically +5/-5mm. Fully tested against multiple stains which can either be removed with standard cleaners (autosol for example) or the specialist clean and shine repair kits.

FAQs

Q: What is the maximum water depth of the basin?

A: 75mm up to the overflow.

Q: What is the distance of the wall fixings?

A: N/A

Q: Whats is the width of the Tapledge?

A: The Tapledge is 114mm wide.

Q: What is the distance from the Taphole centre to Basin Waste?

A: 128mm

Q: What is the overflow kit rating?

A: CL25 (15 litres per minute)