

Technical Data Sheet

Side Inlet Concealed Cistern

ROPER RHODES
TRADE SOLUTIONS

No.	Description	Product Code	Fixings Included?	Gross Weight
1	Side Inlet Concealed Cistern	TR9002	Yes	2.7KG

KEY FEATURES

- pre-assembled concealed cistern
- 3/6 litre adjustable flush option
- pneumatic flush valve and push button operation
- side entry inlet valve
- top & front access
- 0.1-10.0 bar working pressure range
- flushpipe >90° for neat installation
- polystyrene insulation jacket

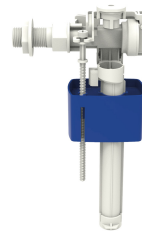

Now comes fitted with air gap inlet valve
Inlet valve WRAS approval number 2105041

DIMENSIONS

DIAGRAMS NOT TO SCALE | ALL DIMENSIONS IN MM TOLERANCE OF ± 5MM
ALL PRODUCTS CONFORM TO BRITISH STANDARDS

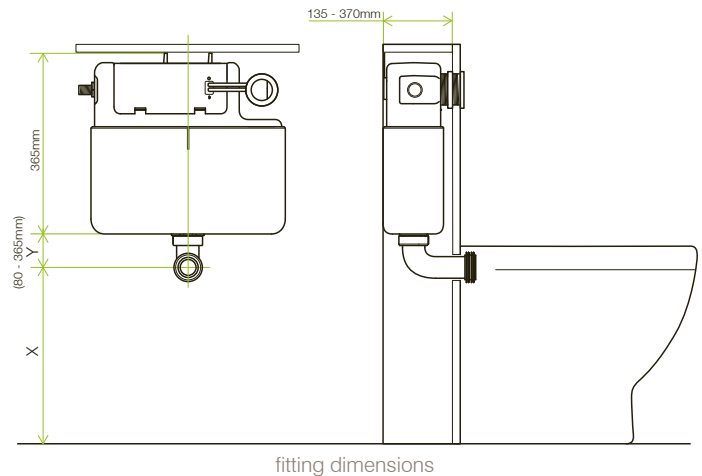
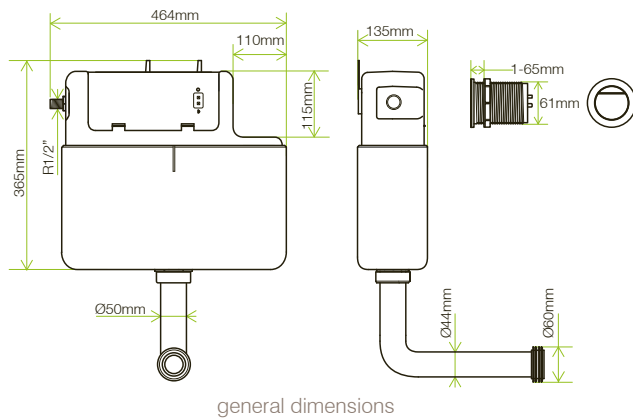

FAQs

Will The Cascade Cistern fit in the Fitted Furniture 500 Slimline BTW Unit?

The Cascade cistern will just fit in the FF 500 slim line BTW but to make the inlet connection it would be necessary to cut a hole in the side panel of the BTW unit. If the customer doesn't want to do this use the Torrent bottom inlet cistern.
(Internal width of RR & R2 FF 500 BTW = 468mm, External width of Cascade cistern = 464mm)

What is the length of the flush inlet pipe to the pan? 390mm.

What is the length of the push button hoses? Approx 700mm.

What is the vertical length of the flush pipe to the tank? 400mm.

Why does the big (full flush) button go down when pressing the small (1/2 flush) button?

This is normal due to the button mechanism - the bellow closes the full flush compartment to reduce the total flush.

When the button is pushed it wont go in or flush?

Check the hose connections from the back of the button to the valve.

Q - What is the minimum flush volume achievable using this cistern?

A - By following the flush valve adjustment process detailed in the instructions a minimum flush level of 4.5L (full) and 2.6L (reduced) can be achieved. To obtain this flush level the setting used should be 4.5 (white float) and 6 (blue float)