

Traditional Exposed Shower Valve

INSTALLATION & AFTERCARE INSTRUCTIONS

INTRODUCTION

Your exposed shower valve is a thermostatic mixer which incorporates a thermo-regulating cartridge to assure users of consistent showering temperatures. The valve has been designed & manufactured to comply with BS EN 1111:1999.

This valve complies with the requirements of the above regulations and installation should be carried out in strict compliance with them.

OPERATING CONDITIONS OF USE

Before installation the operating conditions of use must be checked. The table below contains details of the necessary conditions of operation. This valve is suitable for use with the following systems:

- Gravity fed Hot & Cold (equal pressures)
- Gravity fed Hot & mains Cold (equal pressure)
- Unvented systems
- Gas combination boiler
- Pumped system

Note: If water supply is fed by gravity then supply pressure should be verified to ensure the conditions of use are appropriate for the valve

	High Pressure
Max Static Pressure - BAR	10
Flow Pressure (Hot and Cold) - BAR	1 - 5
Hot Supply Temperature - °C	55 - 65
Cold Supply Temperature - °C	≤ 25

VALVE INSTALLATION GUIDELINES AND COMPLIANCE

The valve must be installed so that it is readily accessible for commissioning and maintenance. The valve must be installed with isolation valves on both the hot and cold water systems as close as possible to the valve; so as to allow the valve to be commissioned and tested correctly. The valve is fitted with integral check valve cartridges which command the water supply, therefore the thermostatic valve is protected against cross-flow due to unbalanced line pressures as required by the Water Supply (Water Fittings) Regulations 1999.

Most problems associated with the operation of thermostatic shower valves are caused by debris in the new pipe work getting into the thermostat. These problems are easily avoided by thoroughly flushing the pipe work BEFORE the shower valve is fitted

INSTALLATION

We recommend this product is fitted by a qualified plumber. Wear suitable eye protection when drilling. Take care when using power tools near water - the use of a residual current device (RCD) is advised. Beware of hidden cables or pipes. When drilling tiled surfaces, a piece of masking tape applied to the wall before marking out the fixing holes will stop the drill wandering.

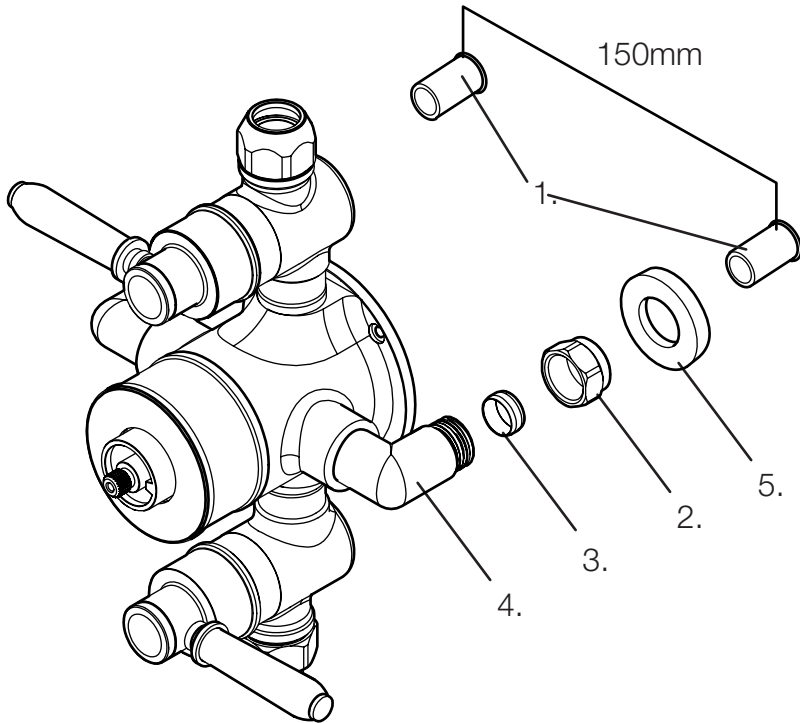

1. Select the valve position considering the overall height of the system including the rigid riser rail and head
2. Prepare the water pipes (1.) at 150mm centres. The end of the pipes should be cut 20-35mm from the finished wall surface
3. Remove the compression nuts (2.) and olive (3.) from the inlet elbows (4.)
4. Line up the valve with the hot and cold inlet pipes ensuring hot inlet is on the left and cold inlet is on the right. Whilst holding the valve in position, mark the fixing positions through the back plate of the valve body
6. Remove the valve and drill four holes into the wall. Fully insert the wall plugs
7. Slide the cover plates (5.) over the pipes to cover the hole around the pipework
9. Secure the valve to the wall with the fixings supplied and at the same time connect the valve to the water supply using the compression nut and olive

SETTING MAXIMUM VALVE TEMPERATURE

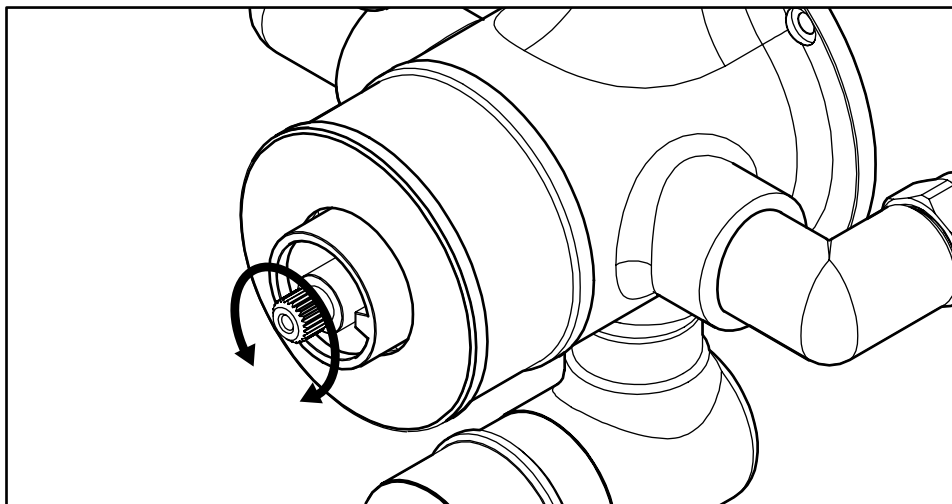

Before installing the temperature handle, the outlet water temperature will need to be tested with a thermometer to ensure that the valve does not exceed 42°C

If the maximum temperature needs to be adjusted, follow the instructions below:

1. Rotate the thermostatic cartridge spindle to adjust the temperature. Rotating the spindle clockwise will reduce the temperature. Rotating the spindle anti-clockwise will increase the temperature.
2. Whilst continuing to test the water temperature, adjust the spindle position until 42°C is reached.
3. Once this temperature is reached, turn off the water supply and leave the cartridge spindle in this position. The valve is now ready to install the temperature handle - which includes a built in temperature stop.

INSTALLING TEMPERATURE HANDLES

With the valve maximum temperature found, the temperature handle can be installed. First, determine which of the following handle types you have and follow the instructions:

For handles with removable indices:

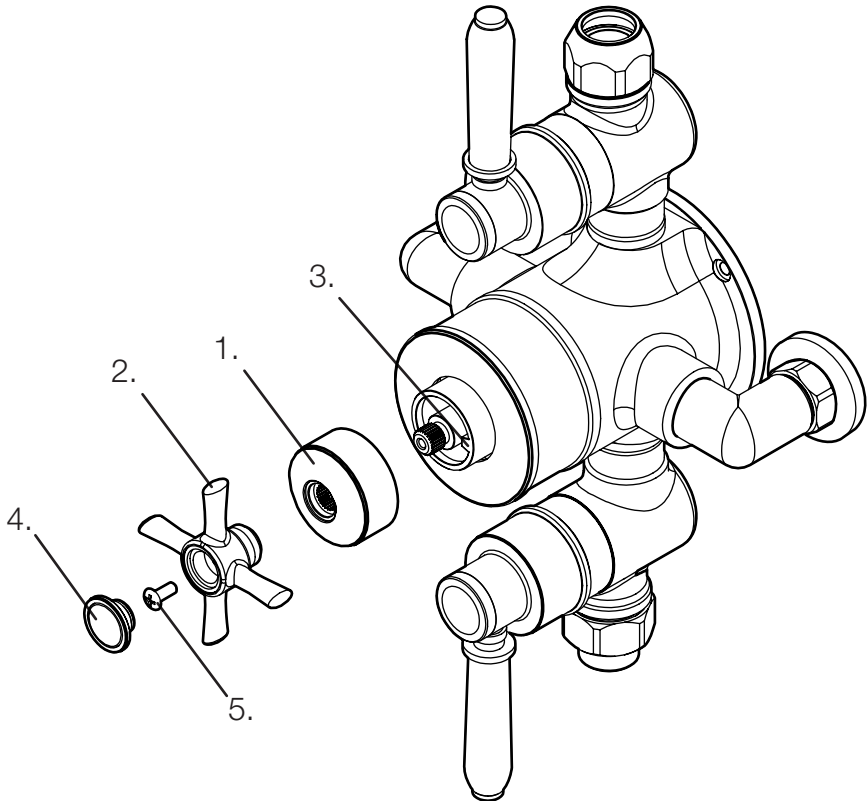

1. The temperature handle comes in two parts - the handle shroud (1.) and the handle body (2.) - the underside of the temperature shroud has a grub screw that acts as a temperature stop.
2. Assemble the handle shroud to the temperature cartridge so that the grub screw touches the tab on the temperature stop (3.) and cannot be rotated any further anti-clockwise.
3. Remove the indices (4.) from the handle body and secure the handle to the cartridge spindle with the fixing screw (5.)
4. Re-assemble the indices to the handle body to cover the fixing screw to finish installation.

INSTALLING TEMPERATURE HANDLES

For handles that are supplied with a brass spindle extender:

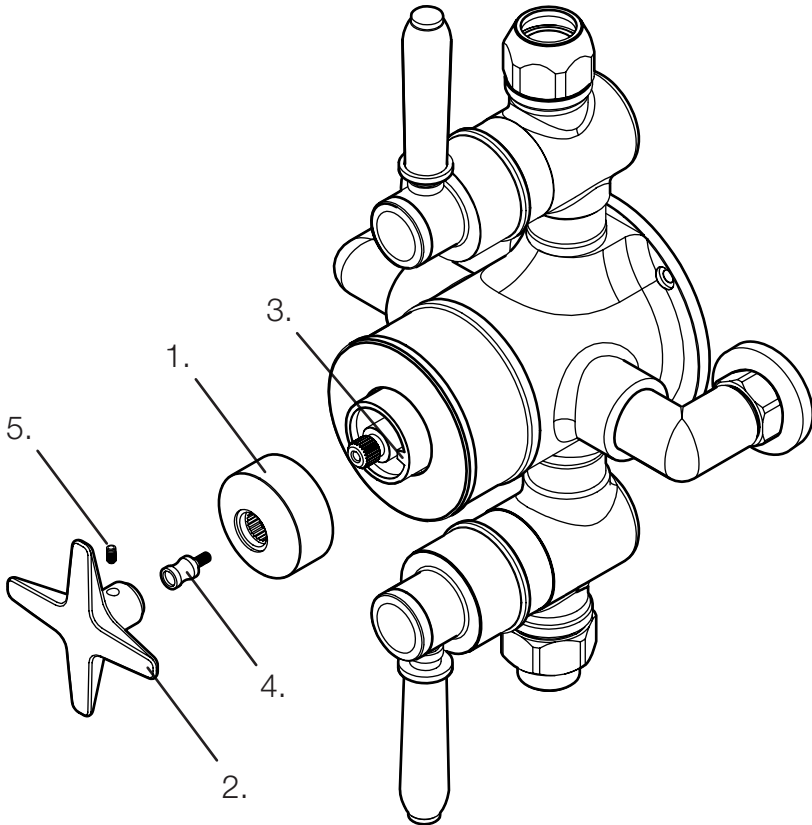

1. The temperature handle comes in two parts - the handle shroud (1.) and the handle body (2.) - the underside of the temperature shroud has a grub screw that acts as a temperature stop.
2. Assemble the handle shroud to the temperature cartridge so that the grub screw touches the tab on the temperature stop (3.) and cannot be rotated any further anti-clockwise.
3. Screw the brass extender (4.) onto the temperature cartridge.
4. Secure the handle body (2.) to the brass extender using the grub screw (5.)

RISER RAIL INSTALLATION

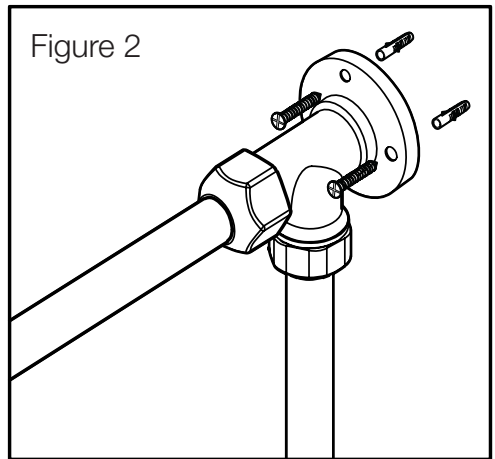
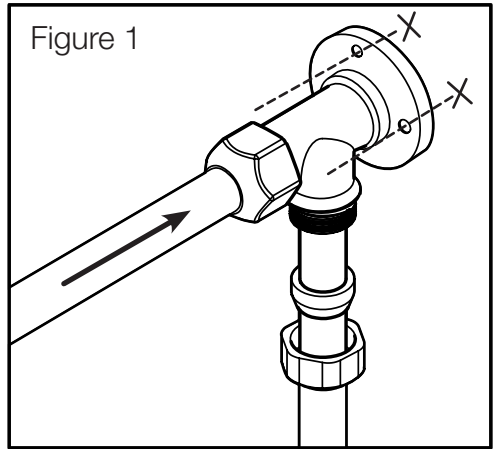
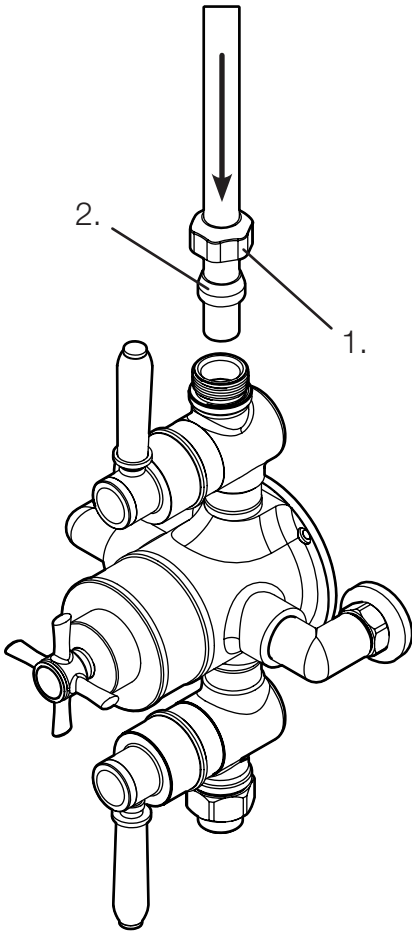

1. The vertical riser rail can be adjusted in height by cutting down the pipe to the preferred length. Make any length adjustments PRIOR to installation.
2. Secure the rail to the valve using the compression fitting (1.) and silicone olive (2.) and tighten with a spanner. Wrap a soft cloth around the compression fitting to avoid scratching.
3. Secure the shower arm and the top of the riser rail to the wall bracket in the same way. Offer the bracket to the wall. Mark the fixing hole positions on the wall and drill a suitable sized hole for the fixings provided. (Figure 1)
4. Secure the wall bracket to the wall with the wall plugs and fixing screws provided (Figure 2)
5. Attach the shower head to the shower arm and handset and hose to the bottom outlet on the valve
6. Check all connections for leaks

TESTING AND ANNUAL SERVICING

We advise that the valves, check valves and filters be regularly serviced particularly in hard water areas. The check valves along with the filters are contained in the inlet elbows. The water supplies must be isolated remotely from the valve before removal.

It is recommended that showers do not exceed 42°C. The valve temperature should never exceed 44°C. Carry out the cold failure test to ensure the valve operates at the correct outlet temperature.

The valve should be tested to ensure correct operation at installation and thereafter at stated intervals decided by the user but never at greater than 12 monthly intervals. The testing will only require a normal thermometer with a scale greater than 65°C. The temperature sensitive element of the thermometer should always be fully inserted into the water flow.

COLD PRESSURE FAILURE TEST

1. Measure the mixed water temperature.
2. Carry out a cold fail/safe shut-off test by using the mains isolation valve to shut off the water to the cold supply. Wait 5 seconds, if water is still flowing check that the water temperature is below 44°C. The flow should stop or reduce to at least 50% of the original flow.
3. Open the cold water isolation valve and measure mixed water temperature. If there is no significant change from the original settings and fail/safe shut off is functioning the valve is working correctly and no further service is required. If the outlet temperature has drifted by more than 2°C, or if the fail/safe function does not work, a full service or re-commissioning is required. We recommend that in these circumstances you contact a plumber for advice as servicing should only be undertaken by a competent person.

TROUBLE SHOOTING

If you require further assistance beyond the guide below, please contact customer services using the contact details on the back of this guide

PROBLEM	SOLUTION
After installation, shower only runs hot or cold - there is no mixed water.	Check if hot & cold supplies are plumbed the wrong way around - or if debris is in the valve.
Shower will not run hot enough when first installed.	The maximum temperature needs to be adjusted - see the temperature setting guide in this manual.
Cold water is running back through the valve and into the hot water system.	Check and clean the check valve cartridges and filters located under the check valve. These may need to be replaced.