

Concealed Thermostatic Shower Valve

INSTALLATION & AFTERCARE INSTRUCTIONS

Suitable for the installation of:

One Function Shower Valve
Two Function Shower Valve
Three Function Shower Valve

Images used in this instruction manual are used for illustrative purposes only; actual product may vary.

INTRODUCTION

Thank you for choosing this shower valve product. This guide covers the installation and commissioning of the shower valve.

This shower valve must be installed in accordance with the Water Supply (Water Fittings) Regulations 1999. We recommend this product should only be fitted by a qualified plumber.

OPERATING CONDITIONS OF USE

Before installation the operating conditions of use must be checked. The table below contains details of the necessary conditions of operation. This valve is suitable for use in both low pressure (BS 1287) and high pressure (BS1111) operating conditions.

Valves must always be operated within either the range for BS 1287 OR BS1111 as described in the table below. Valves cannot operate effectively where a hot or cold pressure system crosses the boundaries of the two ranges. In addition the maximum ratio of unbalanced hot and cold water pressures for the valves to operate effectively is 2:1. Hot or cold pressure must be reduced or boosted so as to work within the required range.

These shower valves are suitable for use with all water supply systems up to a maximum of 5.0 Bar. Operating pressures above 5.0 Bar will require the installation of pressure reducing valves.

	LOW PRESSURE BS1287	HIGH PRESSURE BS1111
MAX STATIC BAR	10 BAR	10 BAR
FLOW PRESSURE (BAR) HOT & COLD	0.1 - 1.0	1 - 5.0
HOT SUPPLY (°C)	55 - 65	55 - 65
COLD SUPPLY (°C)	MAX 25	MAX 25
MIXED WATER (°C)	MAX 44	MAX 44

VALVE INSTALLATION GUIDELINES AND COMPLIANCE

The valve must be installed so that it is readily accessible for commissioning and maintenance. The valve must be installed with isolation valves on both the hot and cold water systems as close as possible to the valve; so as to allow the valve to be commissioned and tested correctly. The valve is fitted with integral check valve cartridge - therefore the thermostatic valve is protected against cross-flow due to unbalanced line pressures as required by the Water Supply (Water Fittings) Regulations 1999.

OPERATION

Your shower valve can only be installed in a **portrait orientation** - with the shower function controls positioned as per the etching on the cover plate.

NOTE: Valves shown below are for illustrative purposes only, actual product may vary.

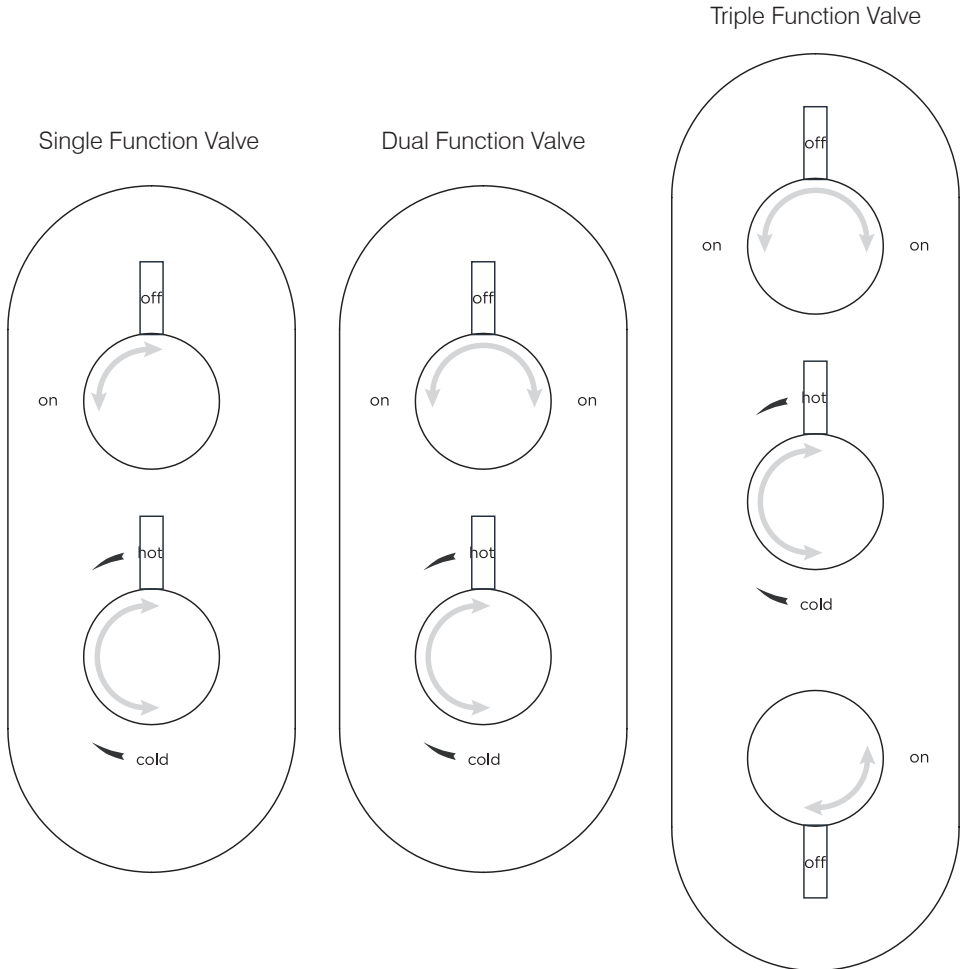

Rotating an outlet selection handle to an 'ON' positions will select the outlet plumbed into that position on the valve. Returning the handle to the 'OFF' position will turn off the water supply to the outlets. For three function valves, the outlet plumbed into the single function control can be used at the same time as one of the other two functions.

Rotating the temperature handle allows for temperature adjustment. Turning the handle in a clockwise direction will reduce the temperature whilst turning the handle in an anti-clockwise direction will increase the temperature to a pre-set maximum temperature (see Setting / Adjusting Temperature section of this guide).

VALVE INSTALLATION

Most problems associated with the operation of thermostatic shower valves are caused by debris in the new pipe work getting into the thermostat. These problems are easily avoided by thoroughly flushing the pipe work BEFORE valve is fitted. Failure to do so may invalidate your guarantee.

The following instructions are suitable for a stud wall installation - 2 Function valve shown for illustrative purposes - installation steps are the same for all valve types.

1. Before starting installation, turn the water supply off. Determine the mounting position of the shower valve and mount the valve to the stud and noggins with fixing screws.

Ensure that when the final finished surface is taken into account, the final wall surface is a minimum of 78mm and maximum of 95mm from the back of the valve.

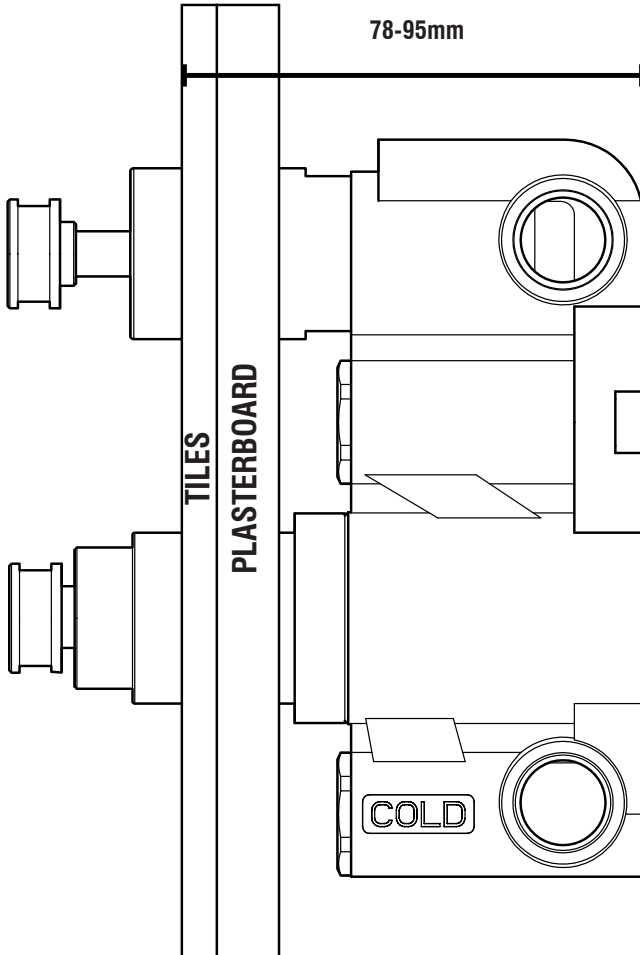

2. With the valve securely mounted, make the appropriate plumbing connections to the hot and cold supplies with PTFE tape. The hot and cold inlets are marked on the valve for easy identification.

NOTE: There are two isolation points on the valve for the hot and cold inlets. These can be screwed in to isolate the inlets during installation and maintenance, as well as reducing flow into the valve to balance hot and cold supplies.

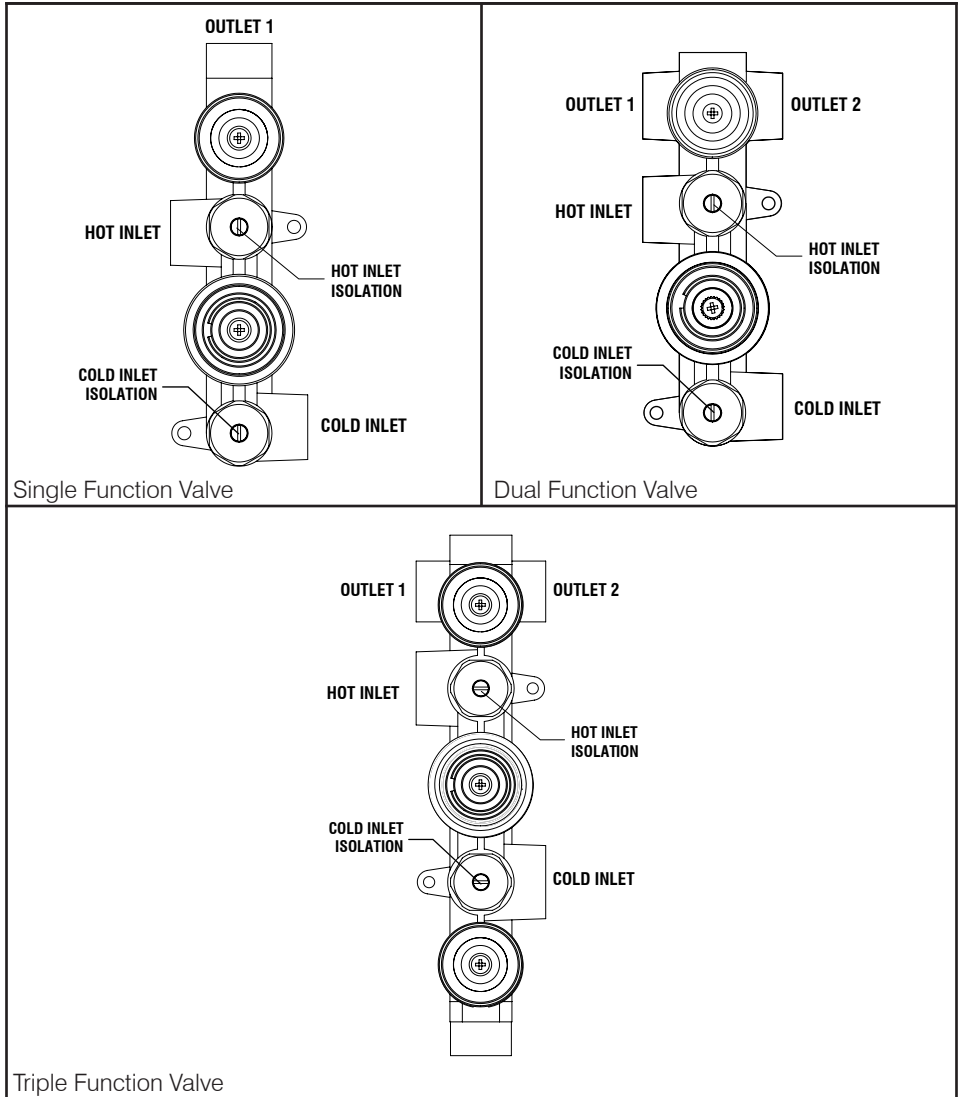

3. Connect the outlet pipework to the chosen shower accessory (wall elbow, shower head, etc.) and turn on the water supply to check for leaks.

4. When all plumbing is checked proceed with installing the final finished wall surface.

Ensure the access hole in the final finished surface can be completely covered by the valve cover plate, allowing the diverter and thermostatic cartridge to be accessed for future maintenance.

SETTING / ADJUSTING TEMPERATURE

5. Before fitting the cover plate and handles, it is necessary to check the valve operates at the correct outlet temperature. To test the outlet water temperature, rotate the temperature control fully anti-clockwise and turn the water supply on. Use a thermometer to check the outlet temperature. The maximum temperature should not exceed 44°C. If the valve does not exceed this temperature, proceed to step 6. If the valve does exceed this temperature, it can be adjusted as follows:

- Remove the fixing screw (A.) and the brass handle attachment (B.) from the thermostatic cartridge.
- Rotate the cartridge spindle (C.) clockwise to reduce the temperature until the temperature reads 44°C
- Reassemble the brass handle attachment, ensuring the tabs on the handle attachment and temperature stop (D.) are touching - preventing the handle from being turned any further anti clockwise.

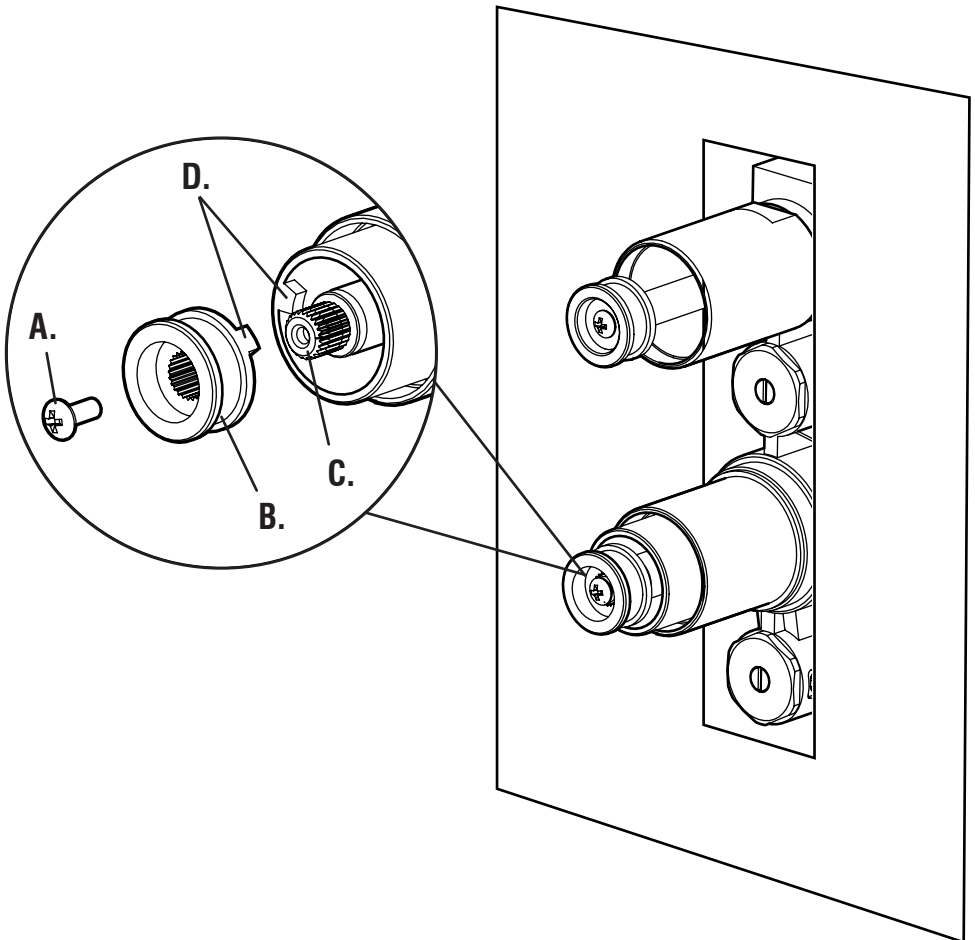

COVER PLATE / HANDLE INSTALLATION

6. Insert the fixing collars (packed inside the handle box) through the holes in the cover plate and secure to the back of the plate using the black rubber retaining O-rings.

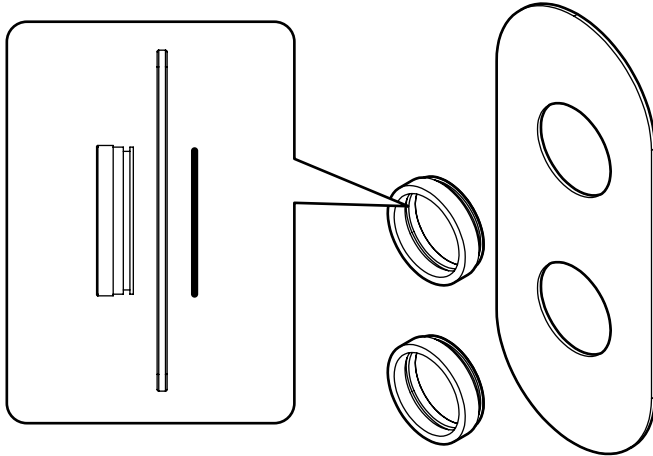

7. Apply a small bead of silicone on the outer edge of the back of the cover plate. Slide the cover plate and trim rings over the valve body up to the finished wall surface, covering the hole. Allow the silicone to fully cure before using the shower system.

8. All handles are attached to the valve using grub screws. Remove any cover caps or handle arms from the handle body and loosen the grub screw to allow the handle to be positioned on the brass valve controls.

Tighten the grub screw so that the handle does not slip when in use and replace any cover caps removed earlier.

NOTE: Ensure that the handle arm is pointing to OFF when flow is shut off and ON when the valve is in operation.

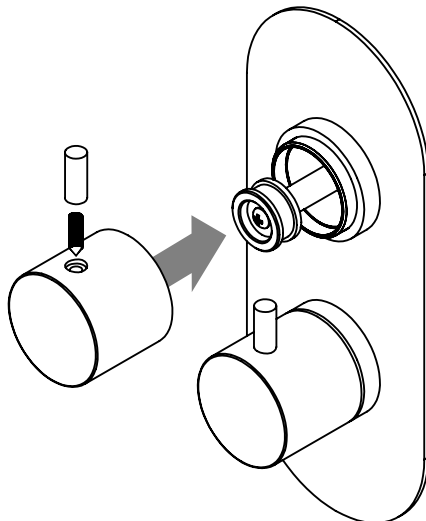

TESTING AND ANNUAL SERVICING

It is recommended that showers do not exceed 44°C. The valve temperature should never exceed 46°C. After commissioning, carry out the cold failure test to ensure the valve operates at the correct outlet temperature.

The valve should be tested to ensure correct operation at installation and thereafter at stated intervals decided by the user but never at greater than 12 monthly intervals. The testing will only require a normal thermometer with a scale greater than 65°C. The temperature sensitive element of the thermometer should always be fully inserted into the water flow.

Follow the procedure below:

1. Measure the mixed water temperature.
2. Carry out a cold fail/safe shut-off test by using the mains isolation valve to shut off the water to the cold supply. Wait 5 seconds, if water is still flowing check that the water temperature is below 44°C. The flow should stop or reduce to a trickle.
3. Open the cold water isolation valve and measure mixed water temperature. If there is no significant change from the original settings and fail/safe shut off is functioning the valve is working correctly and no further service is required. If the outlet temperature has drifted by more than 2°C, or if the fail/safe function does not work, a full service or re-commissioning is required.

We recommend that in these circumstances you contact a plumber for advice as servicing should only be undertaken by a competent person.

TROUBLE SHOOTING

If you require further assistance beyond the guide below, please contact customer services using the contact details on the back of this guide.

PROBLEM	SOLUTION
After installation, shower only runs HOT or Cold - there is no mixed water.	Hot & Cold supplies are plumbed the wrong way around.
Shower will not run hot enough when first installed.	The maximum temperature needs to be adjusted - see the temperature setting guide in this manual.
Cold water is running back through the valve and into the hot water system.	Check and clean the check valve cartridges and filters located under the check valve. These may need to be replaced.