

TECHNICAL DATA SHEET

Secure Fix Slim Wrapover D-Shaped Seat

DC4044-SF

No.	Description	Product Code	Fixings included	Gross Weight
1	Secure Fix Slim Wrapover Seat	DC4044-SF	YES	3KG



DIMENSIONS

DIAGRAMS NOT TO SCALE | ALL DIMENSIONS IN MM | TOLERANCE OF ± 5MM
ALL PRODUCTS CONFORM TO BRITISH STANDARDS

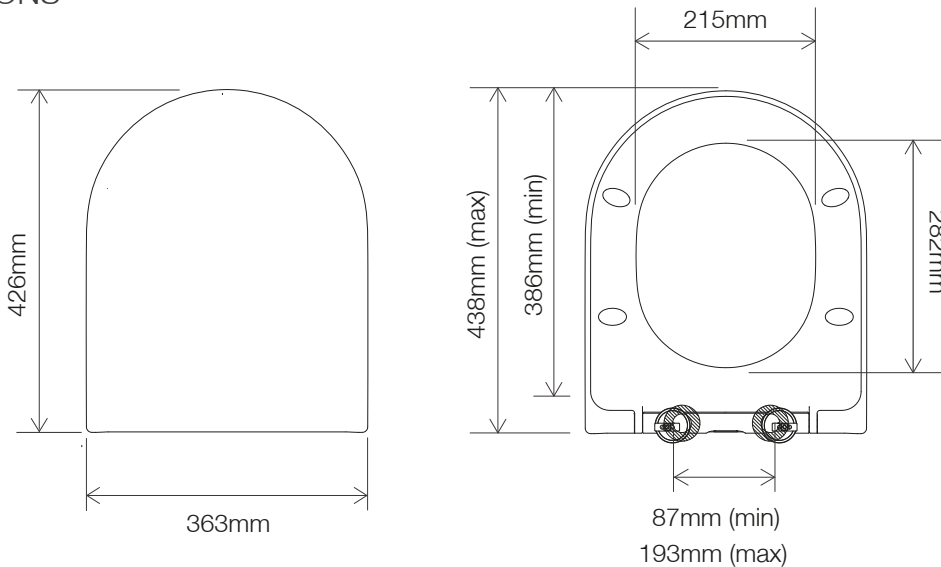

*Dimensions are subject to change, customers are advised to measure actual product before commencing installation.
**Fixing point dimensions are for guidance only. The positions of fixings must be checked when product is received.

FAQs

Q - What is the maximum test load of the seat?
A - 150kg

Q - What are the fixings made from?
A - Stainless Steel Cover Plates, Screws & Anchor Plates, Rubber Washers, Rubber Fixing Plugs.

Q - What finish are the hinge covers supplied with the seat?
A - Chrome

Q - Can the seat hinges be upgraded to a different finish?
A - Yes, the cover caps can be upgraded using DC4019 (black), DC4020 (brass) or DC4030 (gunmetal)

Q - What colour finish is the seat?
A - Alpine White

Key Dimensions Descriptions	Key Dimensions (mm)
Seat/Lid Front to Back	426mm
Seat/Lid Left to Right	363mm
Ring Hole Front to Back	282mm
Ring Hole Left to Right	215mm
Seat Overall Thickness	44mm
Width of Back of Seat	363mm